

# OS02C10 2-megapixel product brief



available in  
a lead-free  
package

## Image Sensor Combines Ultra Low Light and Nyxel™ NIR Technologies for Industry's Best Nighttime Camera Performance

OmniVision's OS02C10 is a 2.9-micron, 2-megapixel image sensor with breakthrough ultra-low-light (ULL) technology. Combining ULL with OmniVision's industry-leading Nyxel™ near-infrared (NIR) technology, the OS02C10 works equally well in all lighting conditions. It can detect incident light in both visible and NIR wavelengths and produce precise color and monochrome images for security applications such as remote surveillance cameras with AI for accurate facial recognition.

Nyxel NIR technology infuses the OS02C10 with exceptional quantum efficiency (QE) of 60% at 850 nm and 40% at 940 nm, which is 2x to 4x better than competing devices. This enables the use of lower-power IR illumination in total darkness, resulting in an estimated 3x reduction in system-level power consumption. Additionally, 940 nm NIR lighting cannot be detected by the human eye in dark indoor settings, while 850 nm light is ideal for outdoor security cameras. The OS02C10's ability to capture crisp, clear images using undetectable 940 nm NIR light means that indoor security cameras will not disturb sleeping occupants, and can be easily concealed from intruders.

The amount of NIR light that a sensor requires to capture high-quality images can be quantified with a new metric called NIR SNR1, which takes into account the QE, pixel size and read noise. The OS02C10 achieves an  $SNR1_{850nm}$  of 23nW/cm<sup>2</sup> and an  $SNR1_{940nm}$  of 31nW/cm<sup>2</sup>, which means designers can reduce IR illumination to consume 2x to 4x less power compared to the competitors' sensors, for the same environment and over the same image-detection range.

The OS02C10 has a superior low-noise design, achieving an SNR1 of 0.16 lux while producing high definition 1080p images. OmniVision's proprietary dual-conversion-gain technology allows this sensor to achieve the industry's best ULL performance, while the 3-frame staggered shutter minimizes motion artifacts and enables a high dynamic range (HDR) of 120 dB. Additionally, these technologies are easily upgradable to 2K and 4K resolution as security systems begin their transition to higher-quality displays.

Find out more at [www.ovt.com](http://www.ovt.com).



OmniVision.

## Applications

- Security Camera
- High Resolution Consumer Camera
- Action Camera

## Product Features

- QE enhancement in NIR range
- support for image size:
  - 1920 x 1080
  - VGA
  - QVGA, and any cropped size
- high dynamic range
- high sensitivity
- programmable conversion gain
- image sensor processor functions:
  - defective pixel cancellation
  - automatic black level correction, etc.
- pixel data: 12b RAW RGB
- SCCB for register programming
- programmable GPIOs
- high speed serial data transfer with MIPI CSI-2 or LVDS
- external frame synchronization capability
- embedded temperature sensor
- one time programmable (OTP) memory

# OS02C10

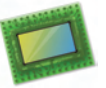

## Ordering Information

- OS02C10-J70A-Z (color, lead-free) 70-pin fan-out package

## Product Specifications

- active array size: 1920 x 1080
- power supply:
  - analog: 2.8V
  - digital: 1.1V
  - I/O pins: 1.8V
- temperature range:
  - operating: -30°C to +85°C junction temperature
- output interfaces: up to 4-lane MIPI CSI-2 or LVDS
- input clock frequency: 6 - 36 MHz
- lens size: 1/2.8"
- lens chief ray angle: 9° linear
- SCCB speed: up to 1 MHz
- scan mode: progressive
- shutter: rolling shutter
- output formats: linear output, dual exposure HDR (long and short), 3-exposure HDR (long, short, and very short), conversion gain programmable in each channel
- maximum image transfer rate:
  - 40X3 fps @ 1080p in 10-bit
  - 30X3 fps @ 1080p in 12-bit
- sensitivity: 32,000 e<sup>-</sup>/Lux-sec (green pixel response at 530 nm illumination)
- dynamic range: >120 dB 3-exposure staggered HDR
- pixel size: 2.9 μm x 2.9 μm
- image area: 5614.4 μm x 3178.4 μm
- package dimensions:
  - fan-out: 8903 μm x 7100 μm

## Functional Block Diagram

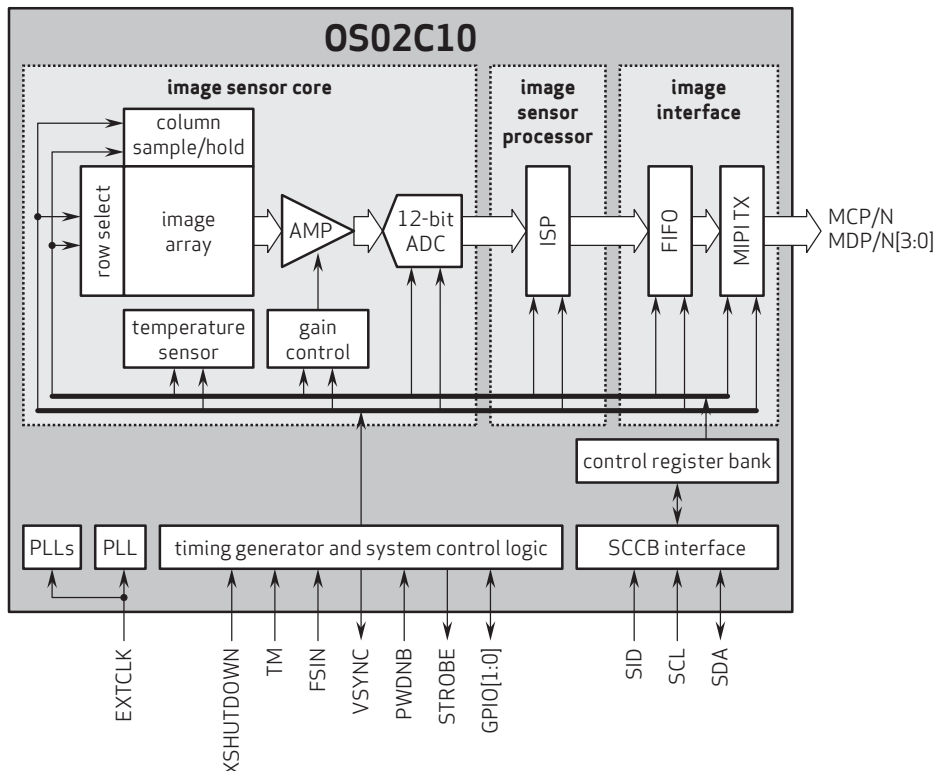

4275 Burton Drive  
Santa Clara, CA 95054  
USA

Tel: + 1 408 567 3000  
Fax: + 1 408 567 3001  
www.ovt.com

OmniVision reserves the right to make changes to their products or to discontinue any product or service without further notice. OmniVision and the OmniVision logo are registered trademarks of OmniVision Technologies, Inc. Nyxel is a trademark of OmniVision Technologies, Inc. All other trademarks are the property of their respective owners.



OmniVision