

TC358860 eDP-->MIPI DSI

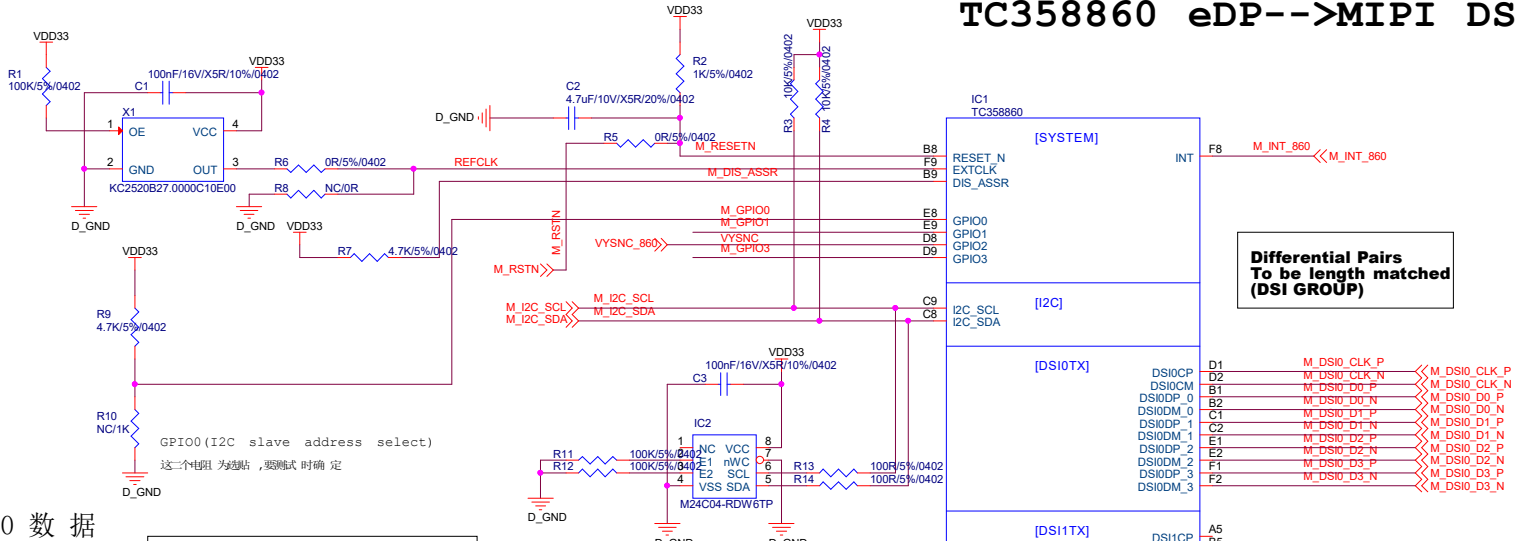

Differential Pairs To be length matched (DSI GROUP)

Differential Pairs To be length matched (DP GROUP)

Differential Pairs To be length matched (DP GROUP)

Differential Pairs in general: To be length matched to within 0.1 mm inter-pair, and 1 mm intra-pair, and 5mm different group (ex. DSI0 and DSI1). Also 100 ohm Differential impedance for each pair. Trace impedance should be controlled to 50 ohms from ground on board.

VBAT为 5V
 DM_OUT & DP_OUT为 USB2.0 数据

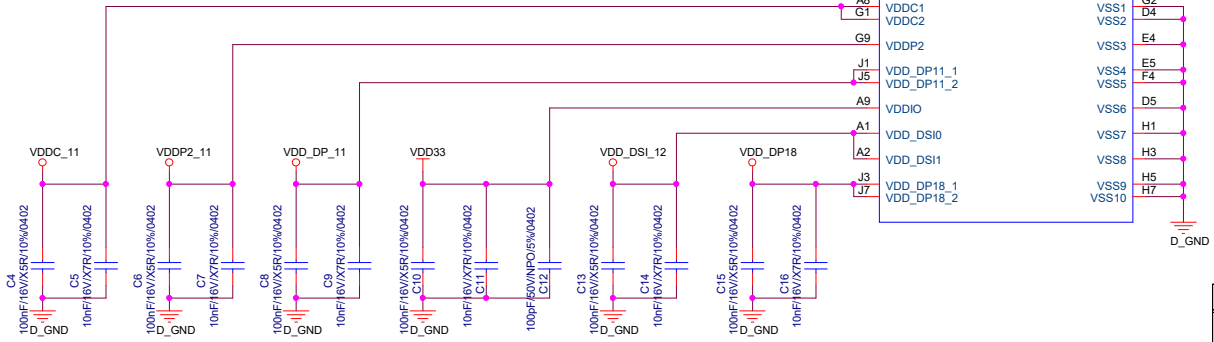
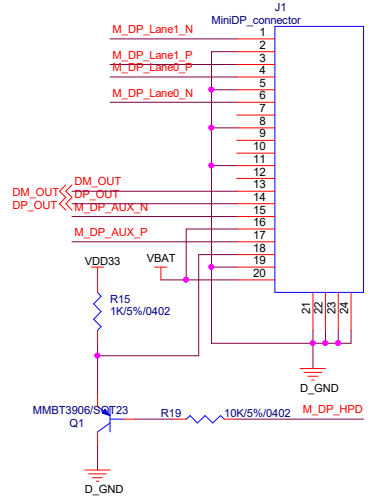

Title	<Title>		
Size	A3	Document Number	<Doc>
Date:	Wednesday, March 25, 2020	Sheet	1 of 4

Rev <RevCode>

TC358867 MIPI DSI-->RGB

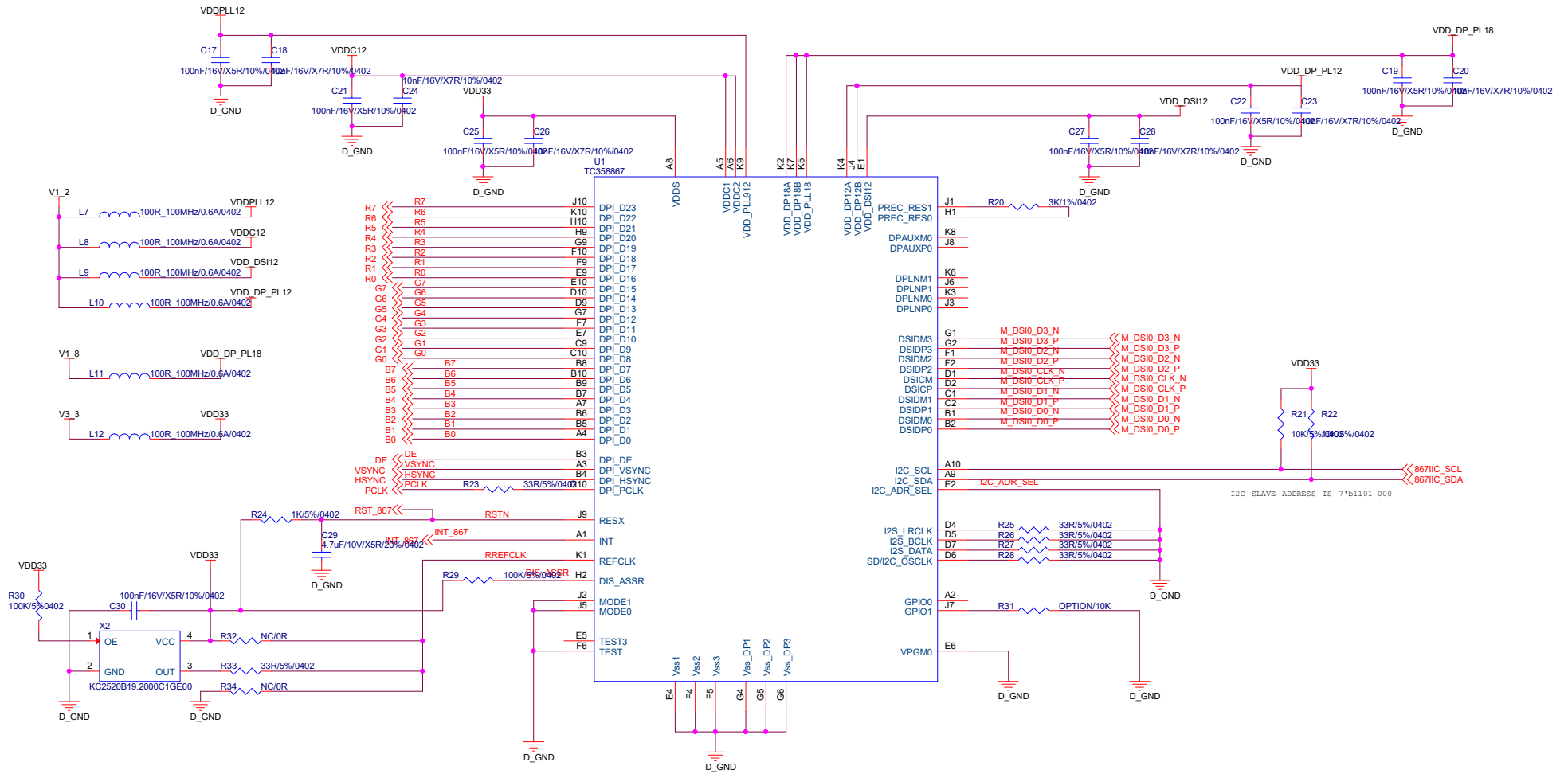

Title	<Title>		Rev
Size	Document	Number	<Rev Code>
A3	<Doc>		
Date:	Tuesday, September 17, 2019	Sheet	2 of 4

1024*768 OLED Interface

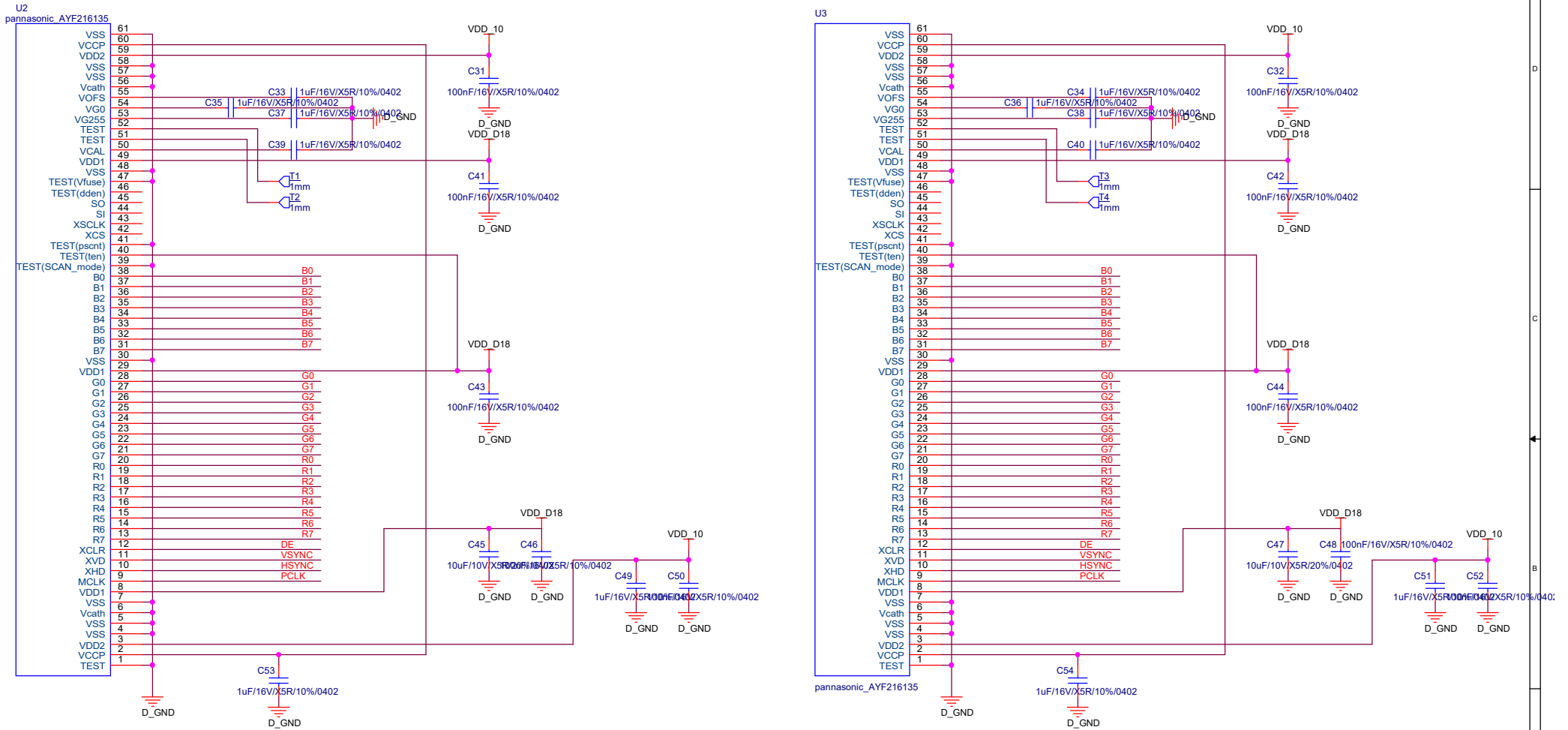

Title	<Title>	
Size	Document Number	Rev
B	<Doc>	<Rev Code>
Date:	Tuesday, September 24, 2019	Sheet 3 of 4

Control Unite

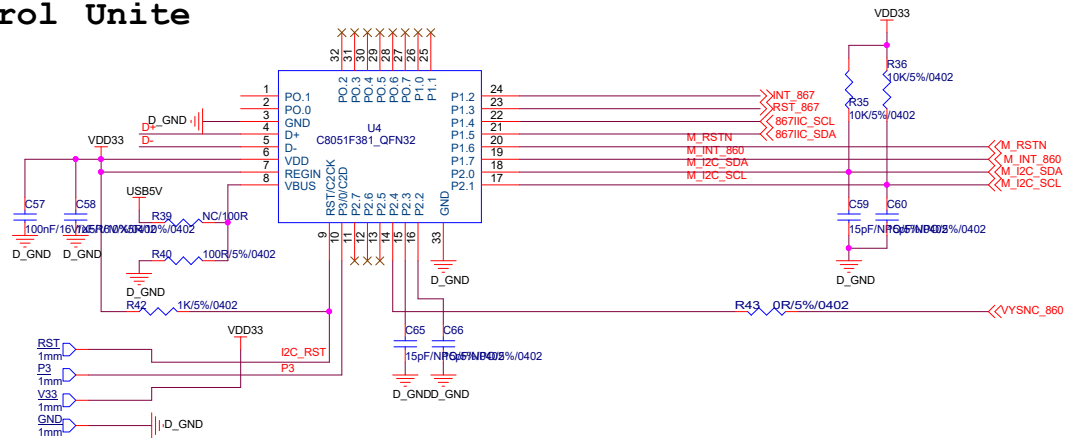

Power 1.8V & 1.1V

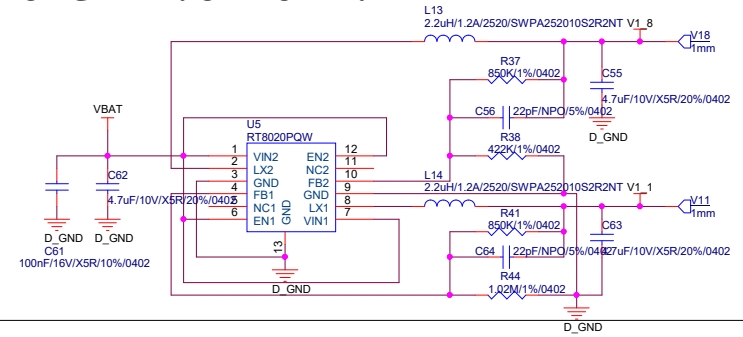

Power 1.2V & 3.3V

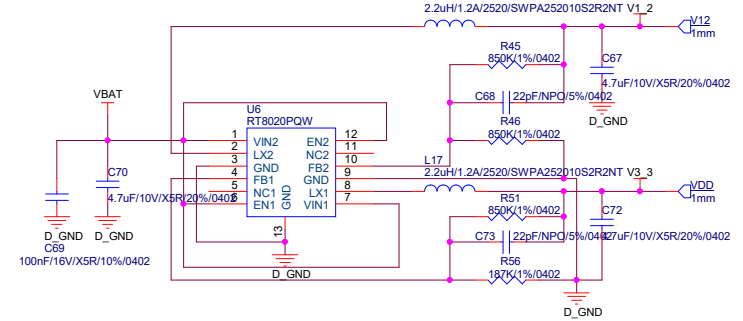

Power for OLED 10V

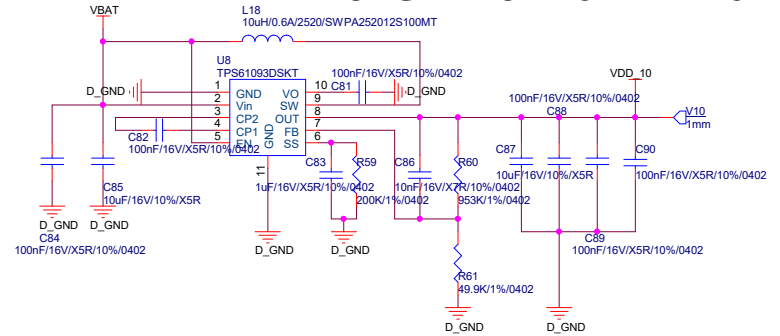

USB HUB

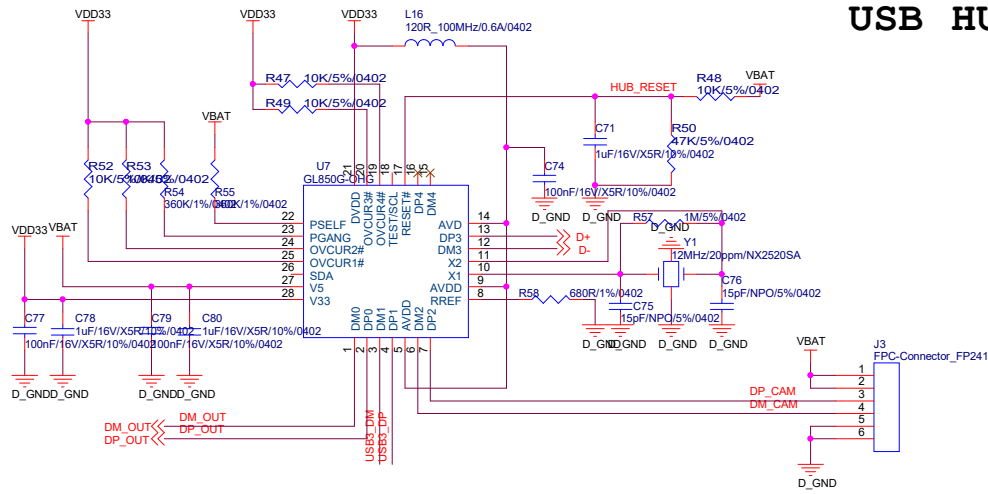

IMU

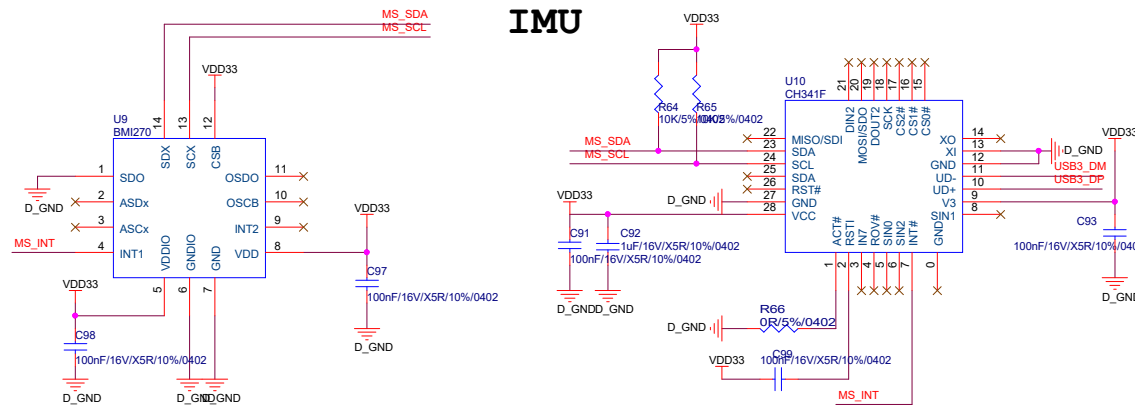

Title	<Title>		
Size	A3	Document Number	<Doc>
Date:	Thursday, May 21, 2020	Sheet	4 of 4