

**MODEL NO :** TM080TDHG01**MODEL VERSION:** 42**SPEC VERSION :** 2.0**ISSUED DATE:** 2017-02-28

- Preliminary Specification  
 Final Product Specification

**Customer :** \_\_\_\_\_

Approved by	Notes

**TIANMA Confirmed :**

Prepared by	Checked by	Approved by
Junwen Du	Longping Deng	KimMin Hong

This technical specification is subjected to change without notice

## Table of Contents

Table of Contents .....	2
Record of Revision .....	3
1 General Specifications.....	4
2 Input/Output Terminals .....	5
3 Absolute Maximum Ratings.....	7
4 Electrical Characteristics .....	8
5 Timing Chart.....	11
6 Optical Characteristics .....	17
7 Environmental / Reliability Test.....	20
8 Mechanical Drawing .....	21
9 Packing Drawing .....	22
10 Precautions for Use of LCD Modules .....	26

### Record of Revision

Rev	Issued Date	Description	Editor
2.0	2017-02-28	Final Specification Release	Junwen Du

TIANMA CONFIDENTIAL

## 1 General Specifications

	Feature	Spec
<b>Display Spec.</b>	Size	8 inch
	Resolution	1024RGBx768
	Technology Type	a-Si
	Pixel Configuration	R.G.B. Stripe
	Pixel pitch(mm)	0.158(H) x0.158(V)
	Display Mode	TM with Normally White
	Surface Treatment	Clear
	Viewing Direction	12 o'clock
	Gray Scale Inversion Direction	6 o'clock
<b>Mechanical Characteristics</b>	LCM (W x H x D) (mm)	183.0x141.0x3.40
	Active Area(mm)	162.05 x 121.54
	With /Without TSP	Without TSP
	Matching Connection Type	FH12A-40S-0.5SH
	LED Numbers	27 LEDS
	Weight (g)	189
<b>Electrical Characteristics</b>	Interface	LVDS
	Color Depth	16.7M
	Driver IC	HX8282A+HX8684B

Note 1: Viewing direction for best image quality is different from TFT definition. There is a 180 degree shift.

Note 2: Requirements on Environmental Protection: Q/S0002

Note 3: LCM weight tolerance:  $\pm 5\%$

## 2 Input/Output Terminals

Matched connector:FH12A-40S-0.5SH

Pin No.	Symbol	I/O	Function	Remark
1	VCOM	P	Common Voltage	
2	VDD	P	Power Voltage for digital circuit	
3	VDD	P	Power Voltage for digital circuit	
4	NC	---	No connection	
5	Reset	I	Global reset pin	
6	STBYB	I	Standby mode, Normally pulled high STBYB = "1", normal operation STBYB = "0", timing controller, source driver will turn off, all output are GND	
7	GND	P	Ground	
8	RXIN0-	I	- LVDS differential data input	
9	RXIN0+	I	+ LVDS differential data input	R[0]~G[0]
10	GND	P	Ground	
11	RXIN1-	I	- LVDS differential data input	
12	RXIN1+	I	+ LVDS differential data input	G[1]~B[1]
13	GND	P	Ground	
14	RXIN2-	I	- LVDS differential data input	
15	RXIN2+	I	+ LVDS differential data input	DE/VS/HS/ B[2]~B[5]
16	GND	P	Ground	
17	RXCLKIN-	I	- LVDS differential clock input	
18	RXCLKIN +	I	+ LVDS differential clock input	
19	GND	P	Ground	
20	RXIN3-	I	- LVDS differential data input	
21	RXIN3+	I	+ LVDS differential data input	R[6]/R[7]/G[6]/G[7]/B[6]/B[7]
22	GND	P	Ground	
23	NC	---	No connection	
24	NC	---	No connection	
25	GND	P	Ground	
26	NC	---	No connection	
27	DIMO	O	Backlight CABC controller signal output	Note1
28	SELB	I	6bit/8bit mode select No	Note2
29	AVDD	P	Power for Analog Circuit	
30	GND	P	Ground	
31	LED-	P	LED Cathode	
32	LED-	P	LED Cathode	
33	L/R	I	Horizontal inversion	Note3
34	U/D	I	Vertical inversion N	Note3
35	VGL	P	Gate OFF Voltage	
36	CABCEN1	I	CABC H/W enable pin	Note4
37	CABCEN0	---	CABC H/W enable pin	Note4

The information contained herein is the exclusive property of TIANMA MICRO-ELECTRONICS Corporation and shall not be distributed, reproduced, or disclosed in whole or in part without prior written permission of TIANMA MICRO-ELECTRONICS Corporation.

38	VGH	P	Gate ON Voltage	
39	LED+	P	LED Anode	
40	LED+	P	LED Anode	

I/O----definition, I----Input, O----Output, P----Power, No used I/O pin please fix to GND level

Note1: PWM output after CABC function;

Note2: LVDS mode 6bits/8bits input select pin,If LVDS input data in 6 bits,SELB must be set To high,If LVDS input data in 8 bits,SELB must be set to low,

Note3: When L/R="0",set right to left scan direction, L/R="1" set left to right scan direction  
When U/D="0",set top to bottom scan direction, U/D="1" set bottom to top scan direction

Note4:

CABC_EN[1:0]	I	<p>CABC H/W enable pin. Normally pull low. When CABC_EN="00", CABC off. (Default mode) When CABC_EN="01", user interface Image. When CABC_EN="10", still Picture. When CABC_EN="11", moving Image.</p>
--------------	---	------------------------------------------------------------------------------------------------------------------------------------------------------------------------------------------------------------------------

### 3 Absolute Maximum Ratings

GND=0V

Item	Symbol	MIN	MAX	Unit	Remark
Power Voltage	VCC	-0.3	7.0	V	Note1
Power Supply Voltage 2	AVDD	-0.5	14.85	V	Base on IC Spec
Power Supply Voltage 3	VGH	-0.3	+42	V	Base on IC Spec
Power Supply Voltage 4	VGL	VGH-42	+0.3	V	Base on IC Spec
Power Supply Voltage 4	VCOM	2.75	4.75	V	Base on Test
Operating Temperature	Top	-20	70	°C	
Storage Temperature	Tst	-30	80	°C	
Relative Humidity Note2	RH	--	≤95	%	Ta≤40°C
		--	≤85	%	40°C < Ta ≤ 50°C
		--	≤55	%	50°C < Ta ≤ 60°C
		--	≤36	%	60°C < Ta ≤ 70°C
		--	≤24	%	70°C < Ta ≤ 80°C
Absolute Humidity	AH	--	≤70	g/m <sup>3</sup>	Ta > 70°C

**Table 3 Absolute Maximum Ratings**

Note1: Input voltage include RxIN0±, RxIN1±, RxIN2±, RxCLKI±.

Note2: Ta means the ambient temperature.

It is necessary to limit the relative humidity to the specified temperature range.  
Condensation on the module is not allowed.

## 4 Electrical Characteristics

### 4.1 Recommended Operating Condition

AGND=GND=0V, Ta = 25°C

Item	Symbol	Min	Typ.	Max	Unit	Remark
Digital Supply Voltage	DVDD	2.7	3.3	3.6	V	-
Analog Supply Voltage	AVDD	11.3	11.5	11.7	V	-
Gate On Voltage	VGH	19.5	20.0	20.5	V	-
Gate Off Voltage	VGL	-7.5	-7.0	-6.5	V	-
Common Electrode Driving Signal	VCOM	3.87	3.97	4.07	V	-

### 4.2 Power Consumption

AGND=GND=0V, Ta = 25°C

Item	Symbol	Condition	Min	Typ.	Max	Unit	Remark
Digital Supply Current	I <sub>VCC</sub>	DVDD=3.3V	-	72.163	-	mA	-
Analog Supply Current	I <sub>AVDD</sub>	AVDD=11.5V	-	49.62	-	mA	-
Gate On Current	I <sub>VGH</sub>	VGH=20.0V	-	0.670	-	mA	-
Gate Off Current	I <sub>VGL</sub>	VGL=-7.0V	-	0.672	-	mA	-
Power Consumption	Pane I & Gamma		-	827	-	mW	-

Note1: Checkered Black pattern for Typ.



### 4.3 Recommended Driving Condition for Backlight

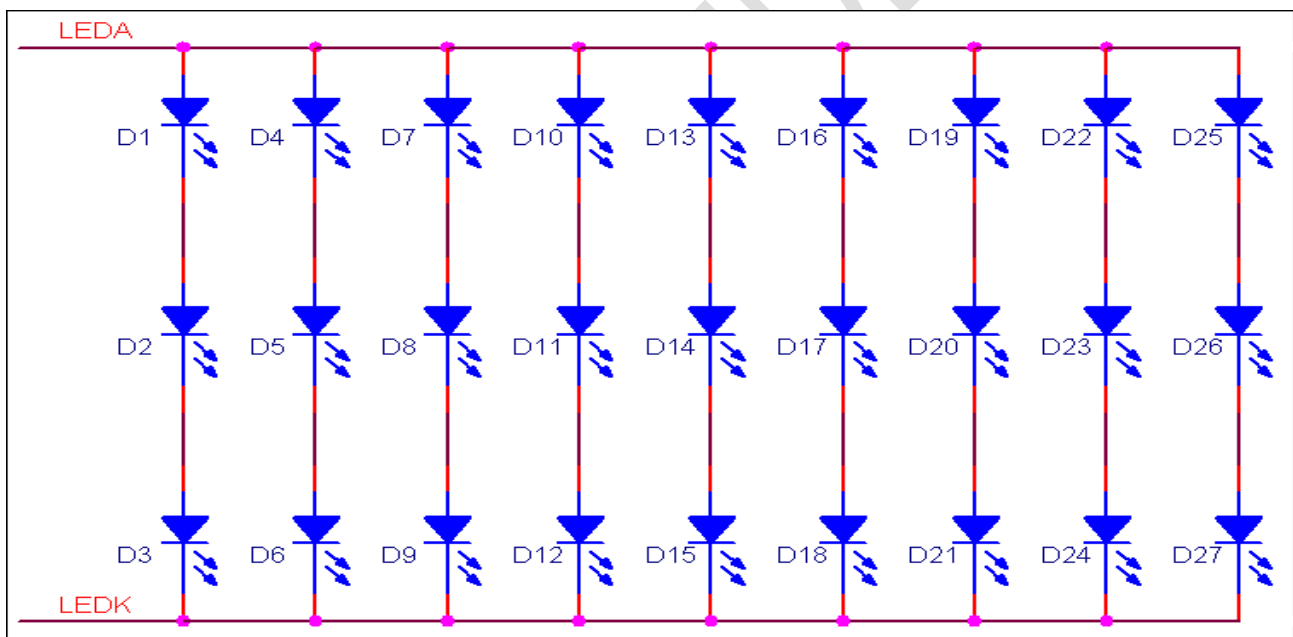
Ta=25°C

Item	Symbol	Min	Typ	Max	Unit	Remark
Forward Current	$I_F$	-	180	225	mA	27LEDs (3 LED Serial, 9 LED Parallel)
Forward Voltage	$V_F$	8.4	9.3	10.2	V	
Backlight Power Consumption	$W_{BL}$	-	1.674	2.295	W	
Operating Life Time	-	20,000	30,000	-	Hrs	$I_F = 20\text{mA}$

Note1: The LED driving condition is defined for each LED module (3 LED Serial, 9 LED Parallel). For each LED:  $I_F (1/9) = 20\text{mA}$ ,  $V_F (1/3) = 3.3\text{V}$ .

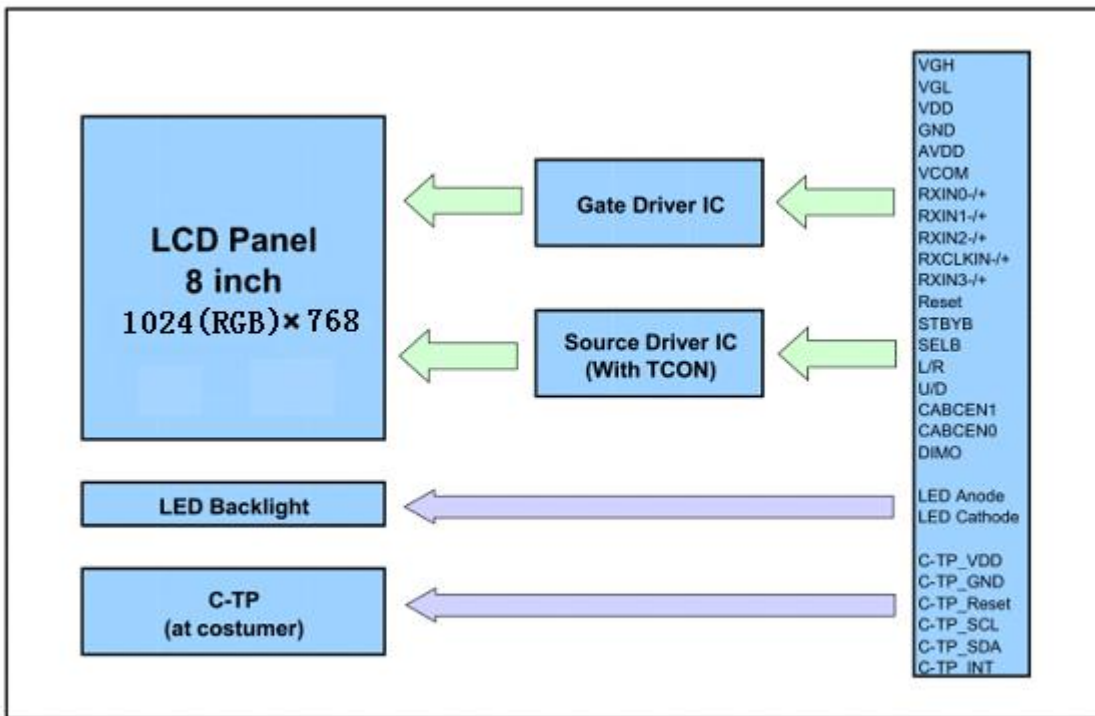
Note2: Under LCM operating, the stable forward current should be inputted. And forward voltage is for reference only.

Note3:  $I_F$  is defined for one channel LED. Optical performance should be evaluated at Ta=25°C only. If LED is driven by high current, high ambient temperature & humidity condition. The life time of LED will be reduced. Operating life means brightness goes down to 50% initial brightness. Typical operating life time is estimated data.



Note4: The LED driving condition is defined for each LED module

4.4 Block Diagram

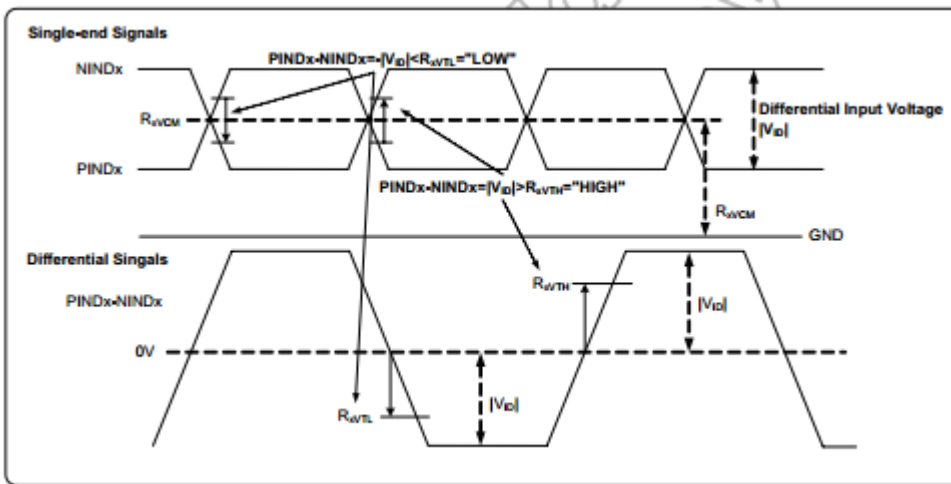


LCD module diagram

## 5 Timing Chart

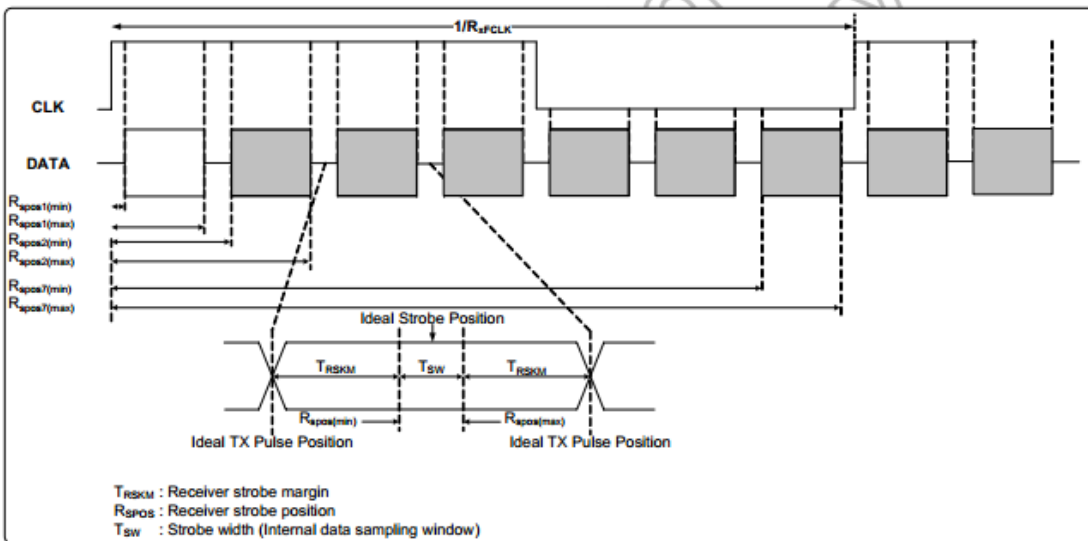
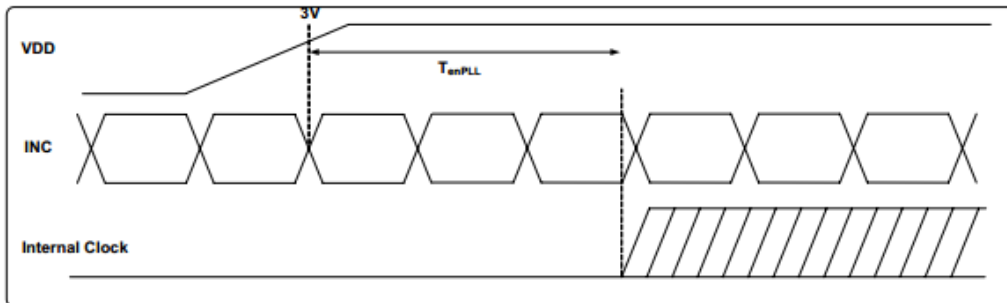
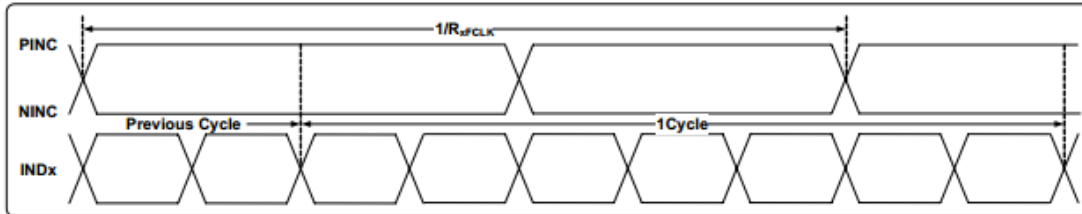
### 5.1 LVDS mode DC electrical characteristics

Parameter	Symbol	Spec.			Unit	Condition
		Min.	Typ.	Max.		
Differential input high Threshold voltage	$R_{XVTH}$	-	-	+0.1	V	$R_{XVCM}=1.2V$
Differential input low threshold voltage	$R_{XVTL}$	-0.1	-	-	V	
Input voltage range (singled-end)	$R_{XVIN}$	0	-	$VDD-1.2+ V_{ID} /2$	V	-
Differential input common Mode voltage	$R_{XVCM}$	$ V_{ID} /2$	-	$VDD-1.2$	V	-
Differential input voltage	$ V_{ID} $	0.2	-	0.6	V	-
Differential input leakage Current	$R_{V_{ISZ}}$	-10	-	+10	$\mu A$	-
LVDS Digital Operating Current	$I_{DDLVDS}$	-	15	30	mA	Fclk=65MHz, VDD=3.3V
LVDS Digital Stand-by Current	$I_{STLVDS}$	-	10	50	$\mu A$	Clock & all Functions are stopped



## 5.2 LVDS mode AC electrical characteristics

Parameter	Symbol	Spec.			Unit	Condition
		Min.	Typ.	Max.		
Clock frequency	$R_{XFCLK}$	20	-	71	MHz	-
Input data skew margin	$T_{RSKM}$	500	-	-	pS	$ V_{ID} =400mV$ $R_{XVCM}=1.2V$ $R_{XFCLK}=71MHz$
Clock high time	$T_{LVCH}$	-	$4/(7 \cdot R_{XFCLK})$	-	ns	-
Clock low time	$T_{LVCL}$	-	$3/(7 \cdot R_{XFCLK})$	-	ns	-
PLL wake-up time	$T_{emPLL}$	-	-	150	$\mu s$	-



Parameter	Symbol	Spec.			Unit	Condition
		Min.	Typ.	Max.		
Modulation Frequency	$SSC_{MF}$	23	-	93	KHz	-
Modulation Rate	$SSC_{MR}$	-	-	$\pm 3$	%	LVDS clock =71MHz center spread

### 5.3 Data input format

#### 5.3.1 LVDS data mapping

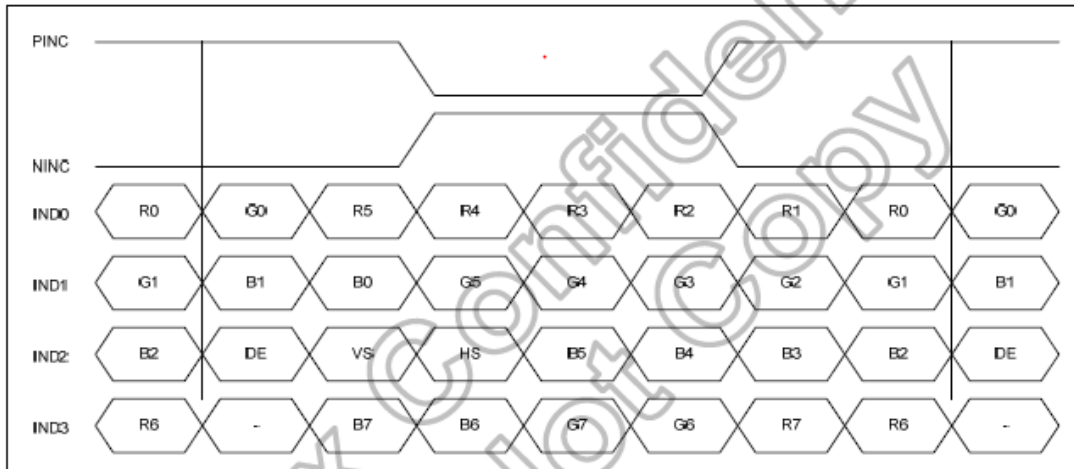


Figure 10.5: 8-bit LVDS Input

#### 5.3.2 Parallel RGB input timing table

- DE mode

Parameter	Symbol	Spec.			Unit
		Min.	Typ.	Max.	
DCLK Frequency	fclk	52	65	71	MHz
Horizontal Display Area	thd	1024			DCLK
HSD Period	th	1114	1344	1400	DCLK
HSD Blanking	thb+ thfp	90	320	376	DCLK
Vertical Display Area	tvd	768			T <sub>H</sub>
VSD Period	tv	778	806	845	T <sub>H</sub>
VSD Blanking	tvbp+ tvfp	10	38	77	T <sub>H</sub>

Table 10.7: DE mode (1024x768)

- HV mode

##### Horizontal timing

Parameter	Symbol	Spec.			Unit
		Min.	Typ.	Max.	
DCLK Frequency	fclk	57	65	70.5	MHz
Horizontal Display Area	thd	1024			DCLK
HSD Period	th	1200	1344	1400	DCLK
HSD Pulse Width	thpw	1		140	DCLK
HSD Back Porch	thbp	160			DCLK
HSD Front Porch	thfp	16	160	216	DCLK

Table 10.8: HV mode horizontal timing (1024x768)

##### Vertical timing

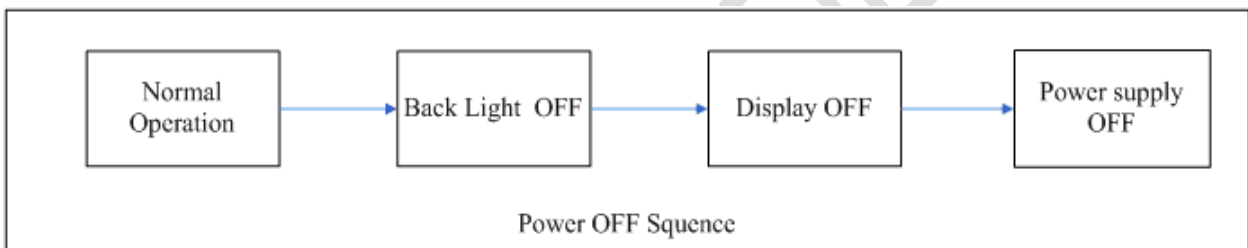
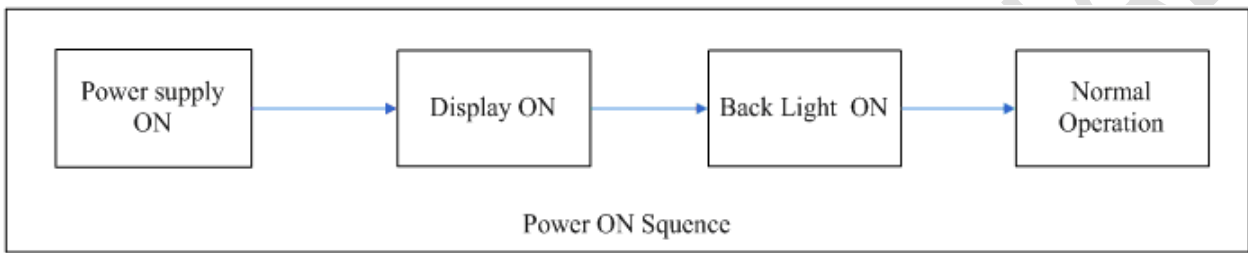
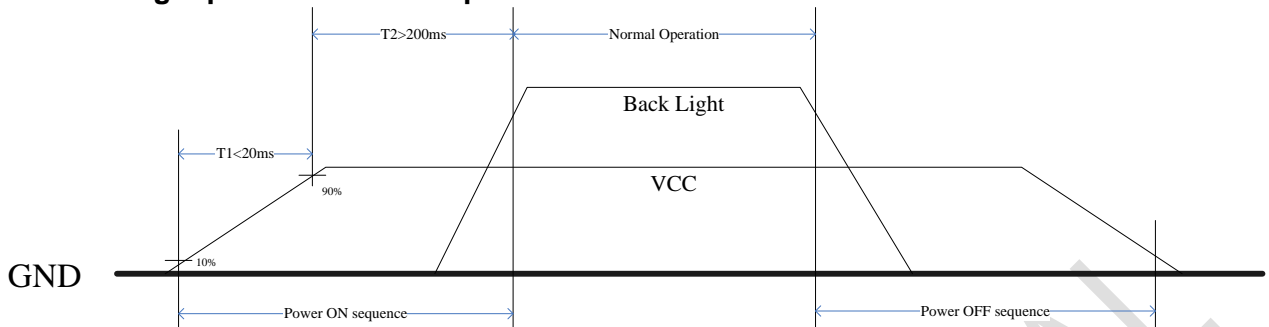
Parameter	Symbol	Spec.			Unit
		Min.	Typ.	Max.	
Vertical Display Area	tvd	768			T <sub>H</sub>
VSD Period	tv	792	806	840	T <sub>H</sub>
VSD Pulse Width	tvpw	1	-	20	T <sub>H</sub>
VSD Back Porch	tvbp	23			T <sub>H</sub>
VSD Front Porch	tvfp	1	15	49	T <sub>H</sub>

Table 10.9: HV mode vertical timing (1024x768)

The information contained herein is the exclusive property of TIANMA MICRO-ELECTRONICS Corporation and shall not be distributed, reproduced, or disclosed in whole or in part without prior written permission of TIANMA MICRO-ELECTRONICS Corporation.

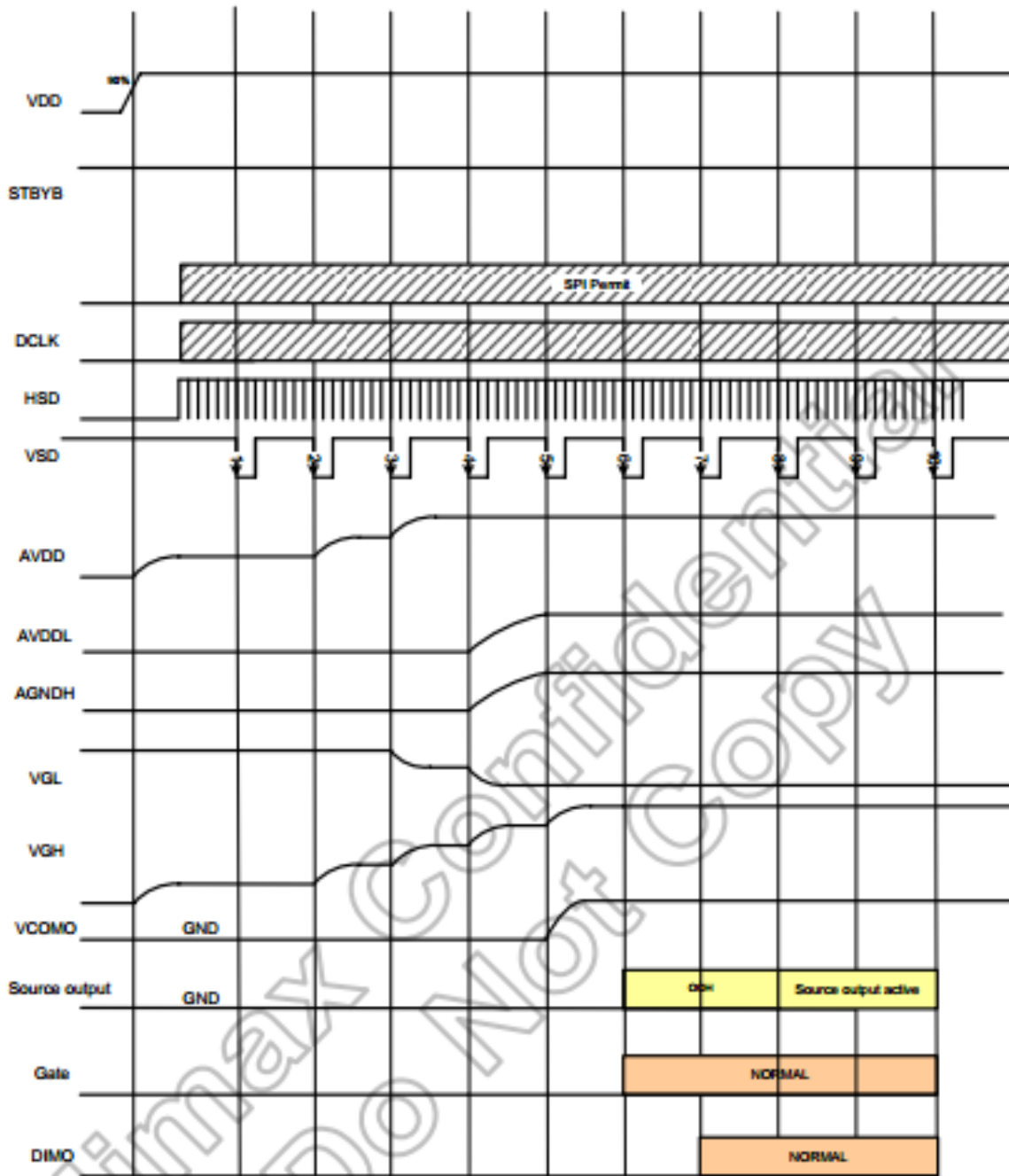
**5.4 Power ON/OFF Sequence**

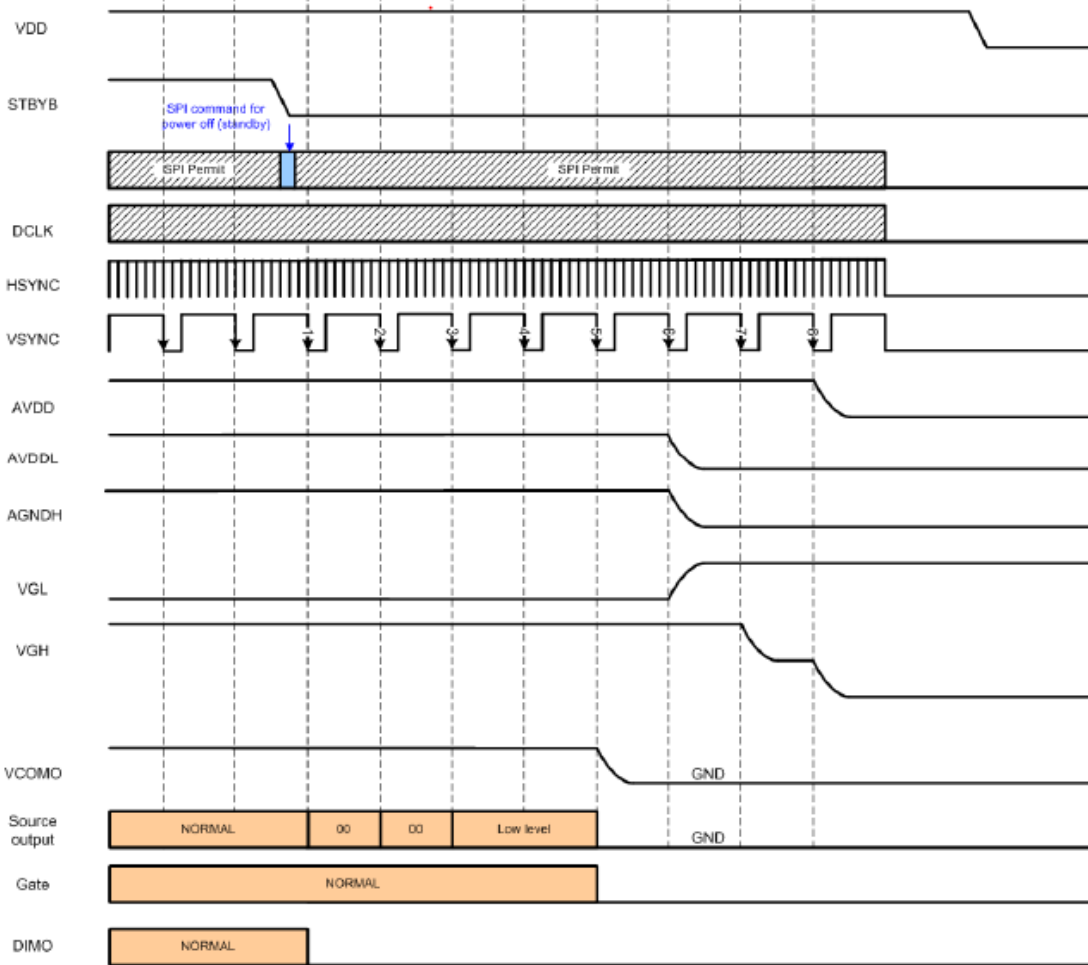
**5.4.1 Back Light power ON/OFF sequence**



**Back Light Power ON/OFF sequence**

5.4.2 System power ON/OFF sequence

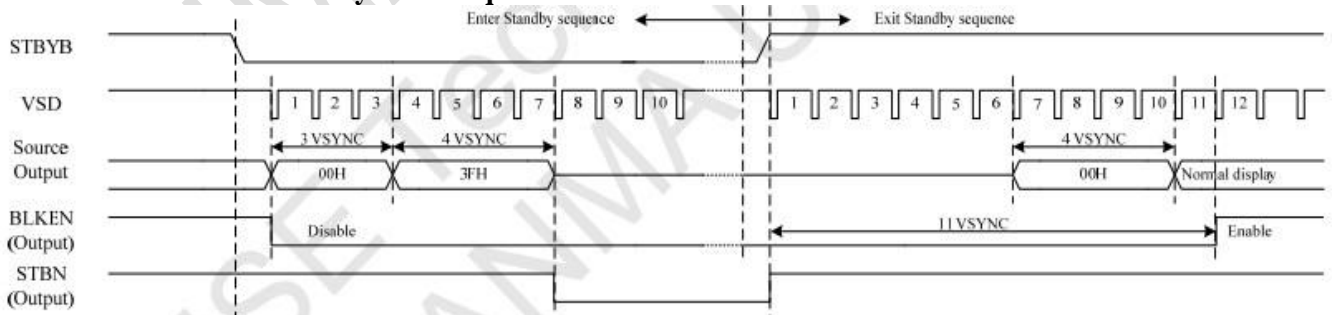




**Figure 8.2: Power off timing sequence**

**Note:** Low level=3FH, when NBW=L (Normally white)  
 Low level=00H, when NBW=H (Normally black)

**5.4.3 Enter and exit standby mode sequence**





## 6 Optical Characteristics

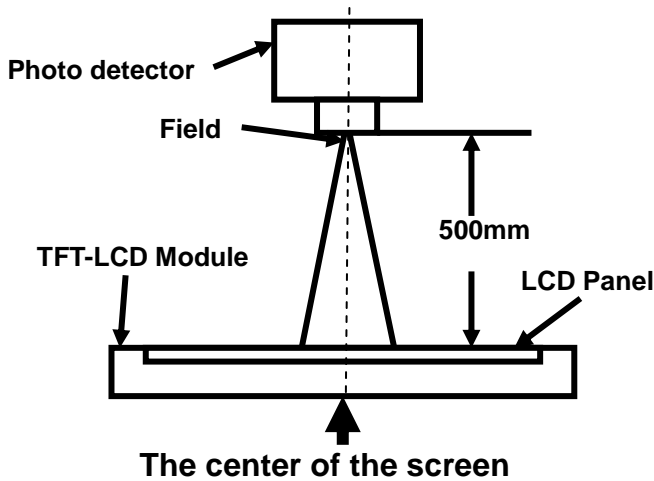
Item	Symbol	Condition	Min	Typ	Max	Unit	Remark	
View Angles	$\theta T$	$CR \geq 10$	70	80	-	Degree	Note2,3	
	$\theta B$		70	80	-			
	$\theta L$		70	80	-			
	$\theta R$		70	80	-			
Contrast Ratio	CR	$\theta=0^\circ$	800	1000	-		Note 3	
Response Time	$T_{ON}$	25°C	-	20	30	ms	Note 4	
	$T_{OFF}$							
Chromaticity	White	Backlight is on	x	0.251	0.301	0.351		Note 1,5
			y	0.273	0.323	0.373		
	Red		x	0.548	0.598	0.648		Note 1,5
			y	0.305	0.355	0.405		
	Green		x	0.292	0.342	0.392		Note 1,5
			y	0.519	0.569	0.619		
	Blue		x	0.101	0.151	0.201		Note 1,5
			y	0.053	0.103	0.153		
Uniformity	U		70	75		%	Note 6	
NTSC			45	50		%	Note 5	
Luminance	L		350	400		cd/m <sup>2</sup>	Note 7	

Test Conditions:

1. IF= 180 mA, and the ambient temperature is 25°C.
2. The test systems refer to Note 1 and Note 2.

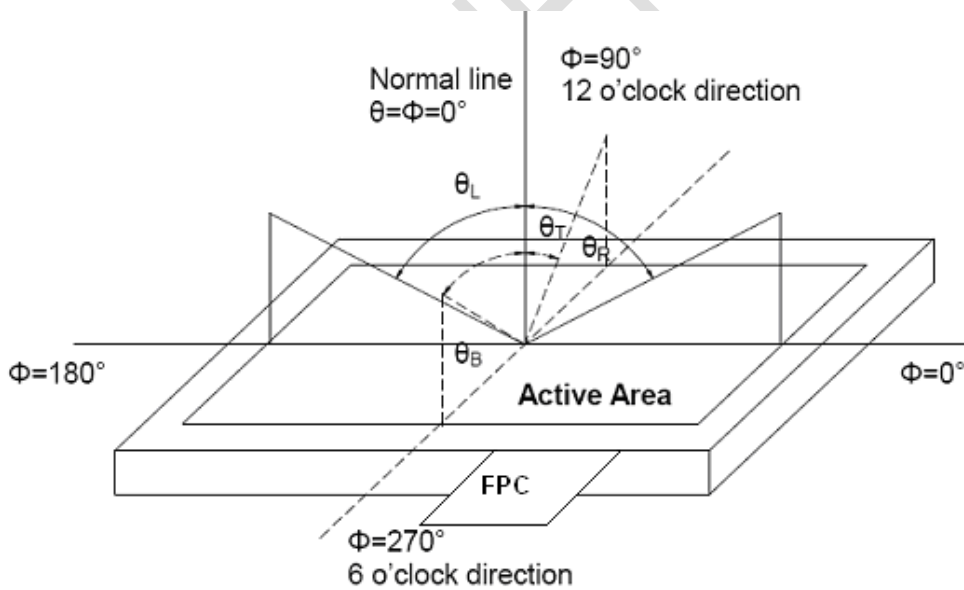
Note 1: Definition of optical measurement system.

The optical characteristics should be measured in dark room. After 5 Minutes operation, the optical properties are measured at the center point of the LCD screen. All input terminals LCD panel must be ground when measuring the center area of the panel.



Note 2: Definition of viewing angle range and measurement system.

viewing angle is measured at the center point of the LCD.



Note 3: Definition of contrast ratio

$$\text{Contrast ratio (CR)} = \frac{\text{Luminance measured when LCD is on the "White" state}}{\text{Luminance measured when LCD is on the "Black" state}}$$

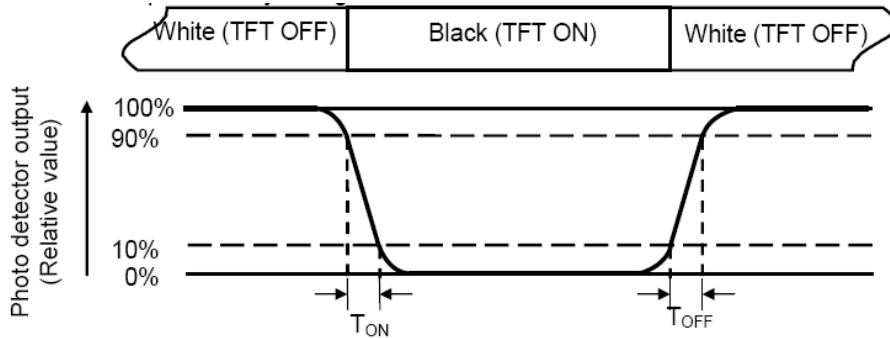
“White state “: The state is that the LCD should drive by  $V_{white}$ .

“Black state”: The state is that the LCD should drive by  $V_{black}$ .

$V_{white}$ : To be determined     $V_{black}$ : To be determined.

Note 4: Definition of Response time

The response time is defined as the LCD optical switching time interval between “White” state and “Black” state. Rise time ( $T_{ON}$ ) is the time between photo detector output intensity changed from 90% to 10%. And fall time ( $T_{OFF}$ ) is the time between photo detector output intensity changed from 10% to 90%.



Note 5: Definition of color chromaticity (CIE1931)

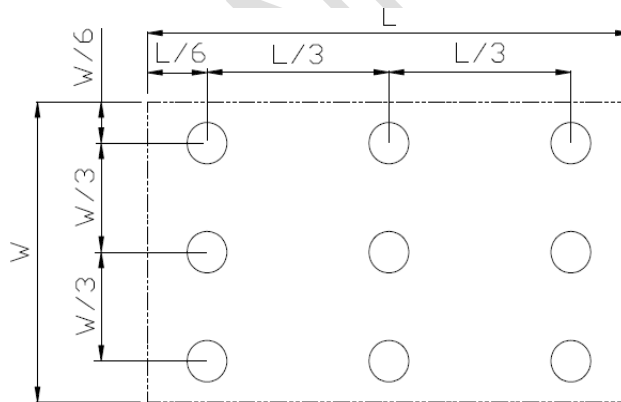
Color coordinates measured at center point of LCD.

Note 6: Definition of Luminance Uniformity

Active area is divided into 9 measuring areas (Refer Fig. 2). Every measuring point is placed at the center of each measuring area.

$$\text{Luminance Uniformity (U)} = L_{\min} / L_{\max}$$

L-----Active area length W----- Active area width



$L_{\max}$ : The measured Maximum luminance of all measurement position.

$L_{\min}$ : The measured Minimum luminance of all measurement position.

Note 7: Definition of Luminance:

Measure the luminance of white state at center point.

**7 Environmental / Reliability Test**

No	Test Item	Condition	Remarks
1	High Temperature Operation	Ts = +70°C, 120 hours (Note1)	IEC60068-2-1:2007 GB2423.2-2008
2	Low Temperature Operation	Ta = -20°C, 120 hours (Note2)	IEC60068-2-1:2007 GB2423.1-2008
3	High Temperature Storage	Ta = +80°C, 120 hours	IEC60068-2-1:2007 GB2423.2-2008
4	Low Temperature Storage	Ta = -30°C, 120 hours	IEC60068-2-1:2007 GB2423.1-2008
5	Storage at High Temperature and Humidity	Ta = +60°C, 90% RH max, 120hours	IEC60068-2-78 :2001 GB/T2423.3—2006
6	Thermal Shock (non-operation)	-30°C 30 min ~ +80°C 30 min, Change time:5min, 20 Cycle	Start with cold temperature, End with high temperature, IEC60068-2-14:1984,G B2423.22-2002
7	ESD	C=150pF, R=330Ω, 5point/panel Air: ±8Kv, 5times; Contact: ±4Kv, 5times (Environment: 15°C~35°C, 30%~60%. 86Kpa~106Kpa)	IEC61000-4-2:2001 GB/T17626.2-2006
8	Vibration Test	Frequency range: 10~55Hz Stroke: 1.5mm Sweep: 10Hz~55Hz~10Hz 2 hours for each direction of X.Y.Z. (6 hours for total)	IEC60068-2-6:1982 GB/T2423.10—1995
9	Mechanical Shock (Non OP)	Half Sine Wave 60G 6ms, ±X, ±Y, ±Z 3times for each direction	IEC60068-2-27:1987 GB/T2423.5—1995
10	Package Drop Test	Height: 80cm, 1corner, 3edges, 6surfaces	IEC60068-2-32:1990 GB/T2423.8—1995

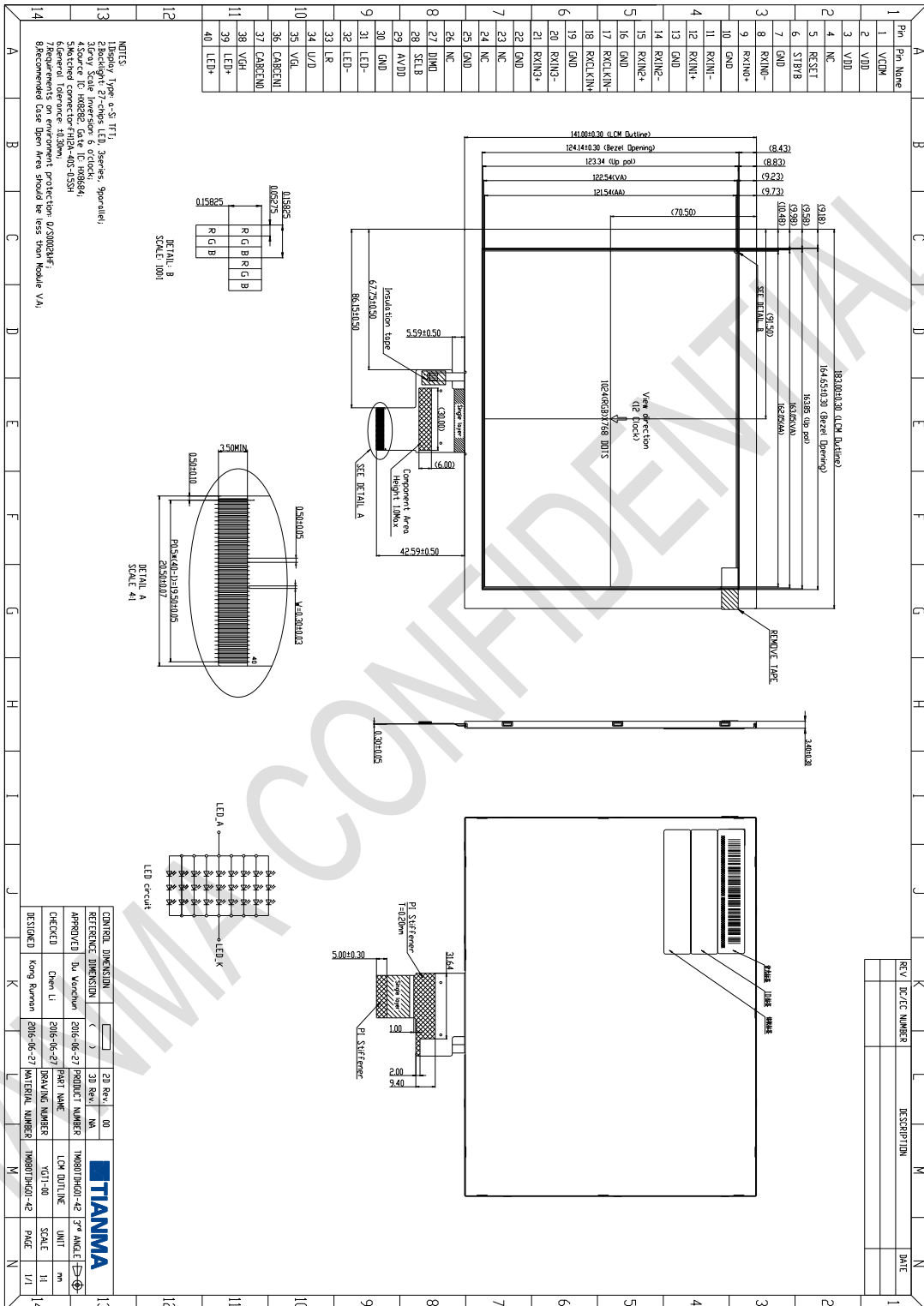
Note1: Ts is the temperature of panel's surface.

Note2: Ta is the ambient temperature of sample.

Note3: Before cosmetic and function test, the product must have enough recovery time, at least 2 hours at room temperature.

Note 4: In the standard condition, there shall be no practical problem that may affect the display function. After the reliability test, the product only guarantees operation, but don't guarantee all of the cosmetic specification.

# 8 Mechanical Drawing



The information contained herein is the exclusive property of TIANMA MICRO-ELECTRONICS Corporation and shall not be distributed, reproduced, or disclosed in whole or in part without prior written permission of TIANMA MICRO-ELECTRONICS Corporation.

## 9 Packing Drawing

### 9.1 Packaging Material

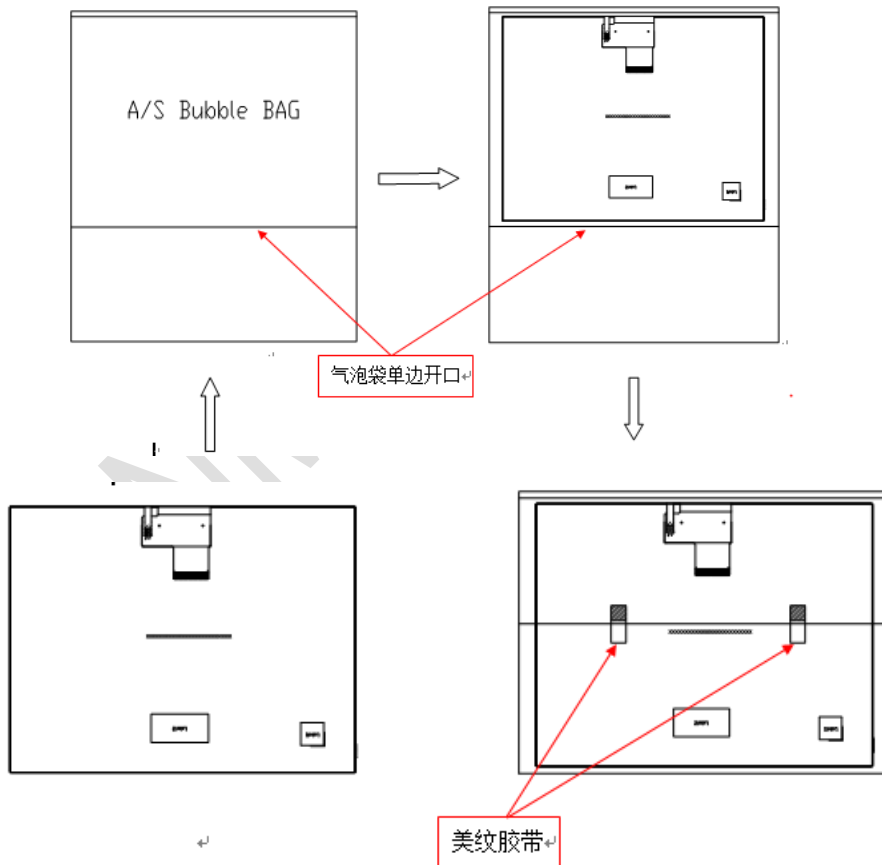
#### Per Carton

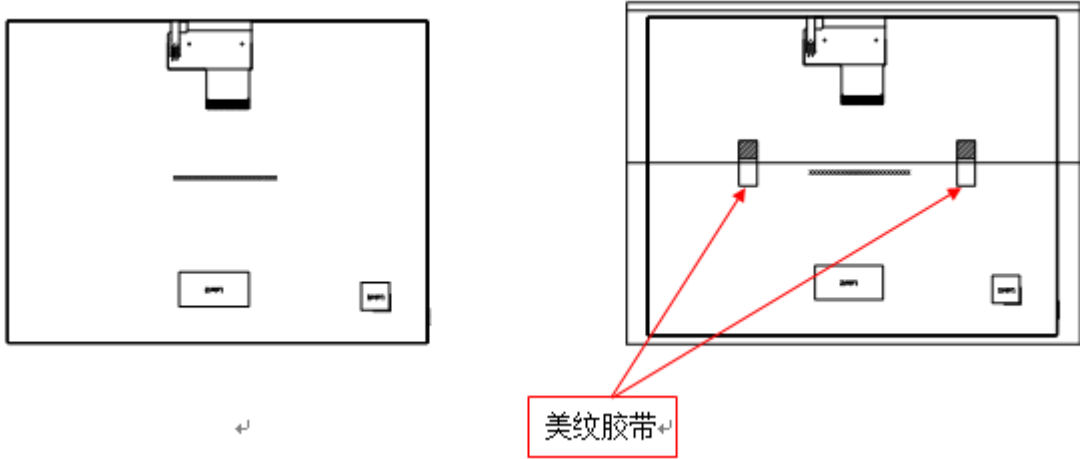
No	Item	Model (Material)	Dimensions(mm)	Unit Weight(Kg)	Quantity	Remark
1	LCM module	TM080TDHG02-40	183×141×3.5	0.189	48	
2	Beauty-grain	Tape	30×10	TBD	96	
3	Partition_1	Corrugated paper	527×348×217	1.323	1	
4	Anti-static Bubble Bag	PE	231×200×3.0	TBD	48	Anti-static
5	Dust-Proof Bag	PE	700×545	0.06	1	
6	Partition_2	Corrugated Paper	505×332×4.0	0.098	2	
7	Corrugated Bar	Corrugated paper	348×173	0.028	6	
8	Carton	Corrugated paper	544×365×250	1.12	1	
9	Total weight	TBD				

### 9.2 Packing instruction

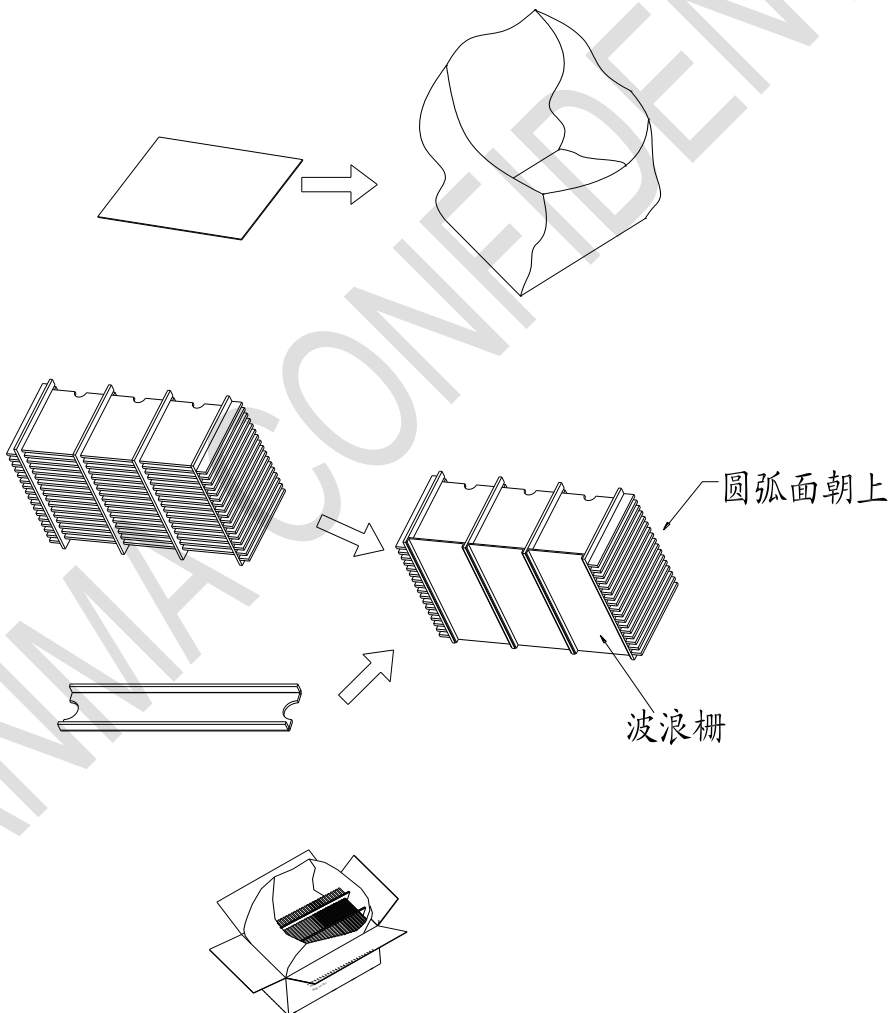
#### 9.2.1 Module packing

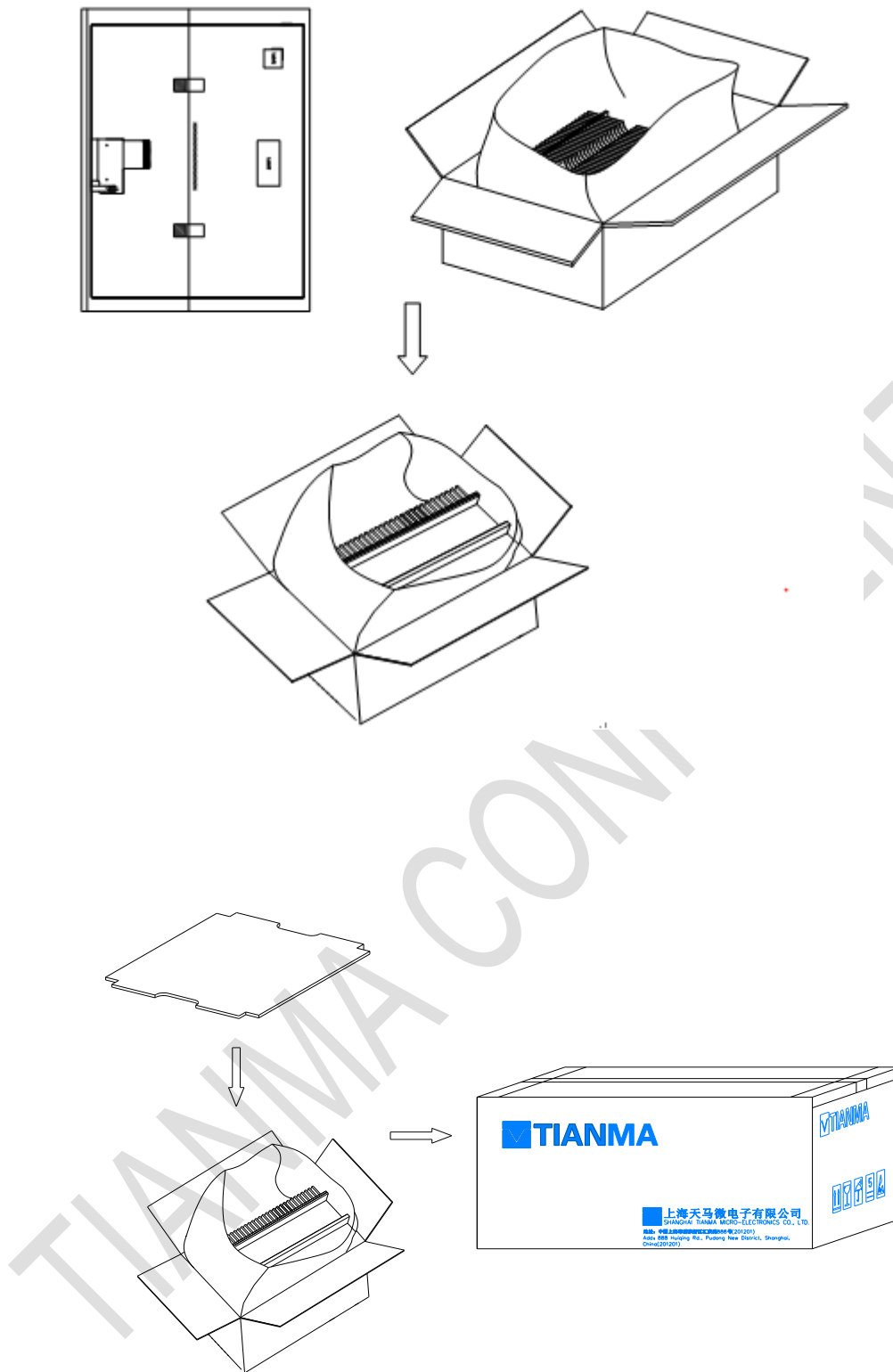
Put the module into the Anti-static bag.



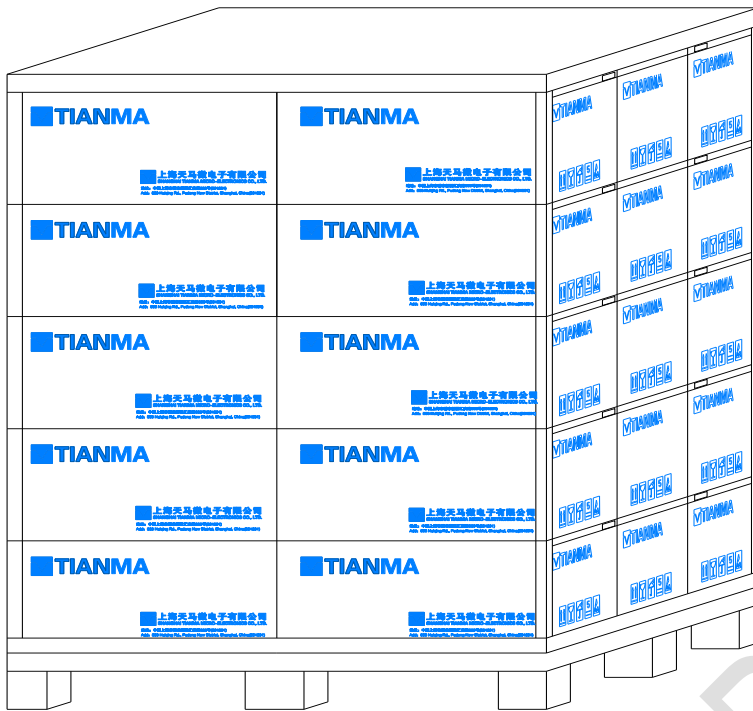


### 9.2.2 Dummy Packing









TIANMA CONFIDENTIAL

## **10 Precautions for Use of LCD Modules**

### **10.1 Handling Precautions**

10.1.1 The display panel is made of glass. Do not subject it to a mechanical shock by dropping it from a high place, etc.

10.1.2 If the display panel is damaged and the liquid crystal substance inside it leaks out, be sure not to get any in your mouth, if the substance comes into contact with your skin or clothes, promptly wash it off using soap and water.

10.1.3 Do not apply excessive force to the display surface or the adjoining areas since this may cause the color tone to vary.

10.1.4 The polarizer covering the display surface of the LCD module is soft and easily scratched. Handle this polarizer carefully.

10.1.5 If the display surface is contaminated, breathe on the surface and gently wipe it with a soft dry cloth. If still not completely clear, moisten cloth with one of the following solvents:

- Isopropyl alcohol
- Ethyl alcohol

Solvents other than those mentioned above may damage the polarizer. Especially, do not use the following:

- Water
- Ketone
- Aromatic solvents

10.1.6 Do not attempt to disassemble the LCD Module.

10.1.7 If the logic circuit power is off, do not apply the input signals.

10.1.8 To prevent destruction of the elements by static electricity, be careful to maintain an optimum work environment.

10.1.8.1 Be sure to ground the body when handling the LCD Modules.

10.1.8.2 Tools required for assembly, such as soldering irons, must be properly ground.

10.1.8.3 To reduce the amount of static electricity generated, do not conduct assembly and other work under dry conditions.

10.1.8.4 The LCD Module is coated with a film to protect the display surface. Be care when peeling off this protective film since static electricity may be generated.

### **10.2 Storage precautions**

10.2.1 When storing the LCD modules, avoid exposure to direct sunlight or to the light of fluorescent lamps.

10.2.2 The LCD modules should be stored under the storage temperature range. If the LCD modules will be stored for a long time, the recommend condition is:

Temperature : 0°C ~ 40°C Relatively humidity: ≤80%

10.2.3 The LCD modules should be stored in the room without acid, alkali and harmful gas.

### **10.3 Transportation Precautions**

10.3.1 The LCD modules should be no falling and violent shocking during transportation, and also should avoid excessive press, water, damp and sunshine.