

## Function Requirement Specification

# GEN3\_2018 Main board only

### approval List

Function	Name	Date	Signature
CEO/Founder	Oliver Richter		
COO/Product Manager	Jimmy De Ridder		

Please copy locally.

## Document History

Date	Version	Author	Change
15/01/2018	0.10	J. De Ridder	Draft version derived from initial Block Diagram with ADI DSP

## Document Confidentiality

For internal & supplier use only.

## Version Numbering

The document numbering consists of 2 numbers: x, y.  
Major changes are indicated by x, minor changes by y.

## Table of Contents

<b>1</b>	<b>General Product Description</b>	<b>4</b>
1.1	Top Level Block diagram	4
1.2	Inputs	4
1.3	Outputs	5
1.4	User interface	5
1.5	Special connectors and modes	5
<b>2</b>	<b>Building Blocks</b>	<b>6</b>
2.1	Aux inputs (Analogue input)	6
2.2	RJ-45 Connectivity	6
2.3	USB-A inputs (#1 and #2)	6
2.4	USB-B input	6
2.5	MCU	6
2.6	DSP	6
2.7	Amplification	6
2.8	Voice IC	7
2.9	USB decoder BU94501	7
2.10	BT BLE-function Nordic nRF51822	7
2.11	Power modes	8
2.12	Power supply & Grounding	8
2.13	Speakers	9
<b>3</b>	<b>Technical specifications</b>	<b>9</b>
3.1	Audio specifications	9
3.1.1	Input specs	9
3.1.2	Output specs (amplifiers)	9
<b>4</b>	<b>Functional requirements</b>	<b>10</b>
4.1	User interface	10
4.1.1	Buttons and controls	10
4.1.2	Visual indicators	10
4.1.3	Audible sound indicators	10
4.2	Volume level and steps	10
4.3	Software	10
4.4	Out of Factory settings	10
4.5	Normal Operating conditions/Climate conditions	11
4.6	Environmental Requirements	11
4.7	Firmware Update	11
4.8	Service documentation	11
4.9	APP design	11

# 1 General Product Description

## 1.1 Top Level Block diagram

### Xounts 2.1CH 2x20W+40W@1%

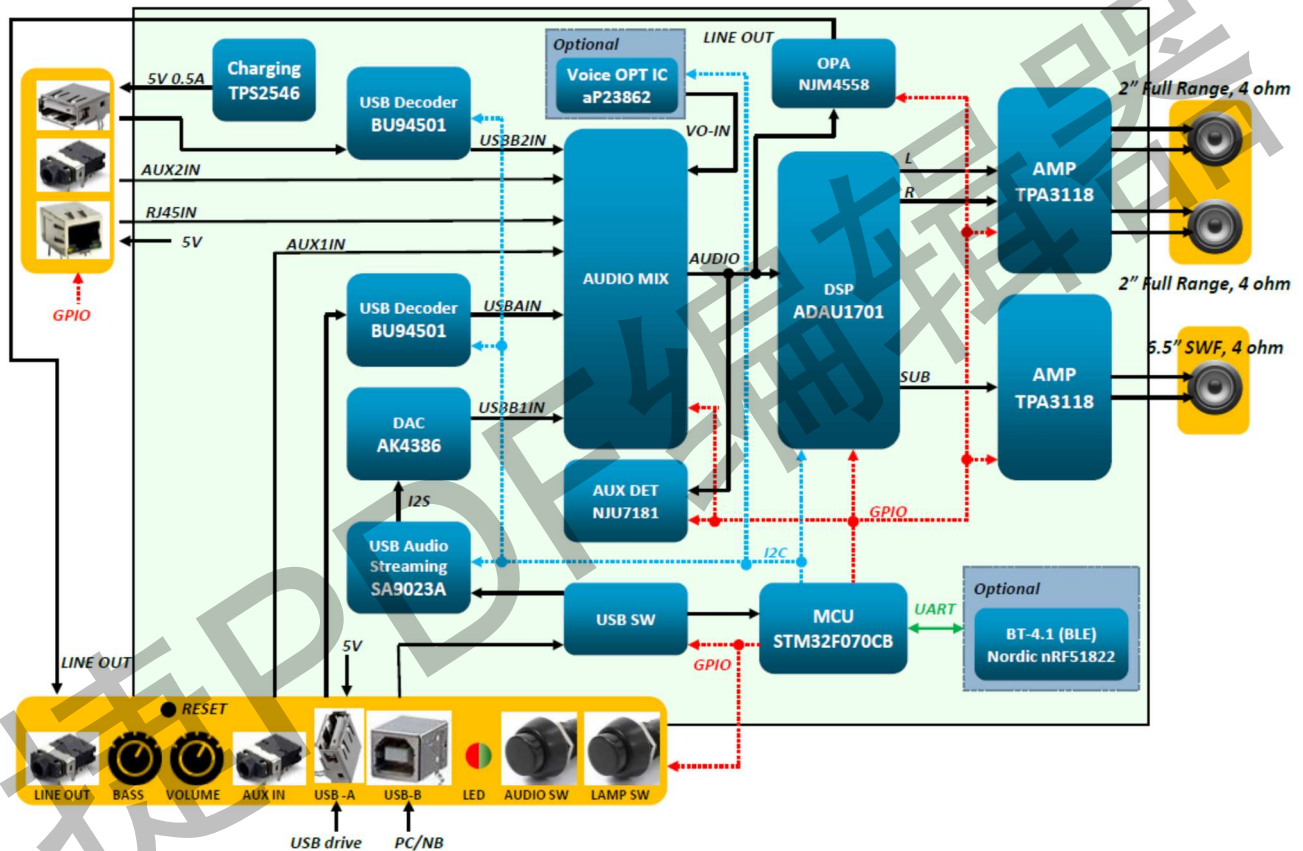

## 1.2 Inputs

### Wired connectivity

- Aux-in #1 (at control board; Analogue input 3.5mm)
- Aux-in #2 (at top base plate; Analogue input 3.5mm)
- USB-A #1 connection (at control board; Digital audio input, power output)
- USB-A #2 connection (at top base plate; Digital audio input, power output)
- USB-B connection (at control board, Digital Audio input connected to PC)
- RJ-45 connection (proprietary connectors; Analogue audio input, DC power output)

### Wireless connectivity

- Bluetooth 4.1 BLE for control purposes ( no BT Audio)

### 1.3 Outputs

- Mono audio socket L speaker connection
- Mono audio socket R speaker connection
- DC-power out via RJ-45
- DC-power out via USB-A #1 & USB-A # 2
- Aux-out at control board as input for other audio devices (3.5mm)

### 1.4 User interface

- 4 knob controls on the base unit control area
- Bi-color LED for power status indication
- Audible feedback (indicators/sounds/beeps)
  - During power-ON
  - Mute (Minimum volume)
  - Maximum volume
  - USB-dongle insert at control panel
  - Spoken software version control (hidden switch)

### 1.5 Special connectors and modes

- 1.5.1.1 Firmware upgrade of MCU: Via USB #1 at front panel
- 1.5.1.2 Sound message upgrade of Flash memory: Via USB #1 at front panel
- 1.5.1.3 App-control via BT BLE of settings and DSP sound processing
- 1.5.1.4 Factory mode: (is hidden part of the application software)
- 1.5.1.5 Service mode: (Not Applicable)

## 2 Building Blocks

### 2.1 Aux inputs (Analogue input)

The analogue input makes it possible to connect Audio products without digital interface.

Implemented by 3.5mm Stereo jack with standard industry contacts.

All analog audio inputs are connected to each other and as such mixed when activating several analog sources. These inputs (#1 & #2) are **hard wired** behind OPAMP buffers together with RJ-45 + USB#1 & #2 and as such **do not use any priority switch setting**. When end-user hears that music is mixed ( 2 or more sources play at same time), he can decide which one to disconnect or deactivate.

Note: hardwiring inputs **shall NOT cause humming noise** from open floating inputs (which act as antennas for noise).

### 2.2 RJ-45 Connectivity

This general purpose interface can be used as audio interface for accessory products using a proprietary RJ-45 connection. This interface contains stereo analog input and 5V DC power output as supply for the accessory product.

The additional unused lines from the 8-pin interface need to be routed to MCU for future developments

### 2.3 USB-A inputs (#1 and #2)

USB #1 & #2 have a double function (5Vdc 2000mA):

- Streaming USB audio (from USB-memory stick)
- Charging of accessories @max5V 2000mA

**NOTE !:** There is a possibility that USB-A #2 near the RJ45 socket has to be **split into 2 USB-A sockets**, so one socket can deliver 1000mA and the second one can deliver 2000mA. (The driving chip for this need to be cable of handling such currents.

### 2.4 USB-B input

This input is used for connection to PC or laptop in order to playback any soundcard music running on the computer. This is designed by the USB Implementers Forum to prevent connecting a host to another host, which could cause a short circuit. The PC is the host and as such, the downstream device need to use another connector (e.g. printers or scanners). The connection cable between PC and loudspeaker will be a USB Type A to Type B.

### 2.5 MCU

Western brand MCU (e.g. TI, ADI, NXP, Atmel, ST Micro Electronics, etc)

Proposal to use ST STM32 series.

### 2.6 DSP

Need to use ADI's chip ADAU1701 which is easy to implement and gives design flexibility through ADI Sigma Studio tool.

### 2.7 Amplification

Amplifiers based on Class D technology. Proposal to use TI series. The TPA31xxD2 series are stereo efficient, digital amplifier power stage for driving speakers up to 100 W / 2  $\Omega$  in mono. The high efficiency of the TPA3130D2 allows it to do 2  $\times$  15 W without external heat sink on a single layer PCB. **The TPA3118D2 can even run 2  $\times$  30 W / 8  $\Omega$**  without heat sink on a dual layer PCB. If even higher power is needed the TPA3116D2 does 2  $\times$  50 W / 4  $\Omega$  with a small heat-sink.

## 2.8 Voice IC

This function is designed to record and store the voice messages needed during certain events during operation of the product interfaces. The short voice messages will be played during:

- power-ON
- Mute (Minimum volume)
- Maximum volume
- USB-dongle insert at control panel
- Spoken software version control (hidden switch)

The blockdiagram shows e.g. aP23862 from Taiwan based APLUS company but this chip is OTP only, so has to be change to MTP version (Multi Time Program) version like aMTPxxM Series .

The final Brand can be chosen after alignment with customer.

## 2.9 USB decoder BU94501

BU9450xAxxx series are WAV/AAC/WMA/MP3 decoder LSI which contains USB host, SD card I/F, audio DAC, system controller, regulator for internal CORE power supply.

Supports SDHC memory cards and supports MMC, mini-SD and micro-SD cards.

Supports audio line outputs from built-in 1bit-DAC.

Supports digital audio outputs of the I2S format, the EIAJ format and those and the digital audio interface (SPDIF).

Builds in sound effects including POPS, JAZZ, ROCK, CLASSIC, R&B and Bass Boost.

Can control from the master microcomputer using the I2C interface.

Can analyses and read other file name in memory while playing the current music.

Supports repeat within the memory, repeat within folder and repeat with single tune

## 2.10 BT BLE-function Nordic nRF51822

The nRF51822 is a powerful, highly flexible multiprotocol SoC ideally suited for Bluetooth® low energy and 2.4GHz ultra low-power wireless applications. The nRF51822 is built around a 32-bit ARM® Cortex™ M0 CPU with 256kB/128kB flash + 32kB/16kB RAM for improved application performance.

nRF51822 incorporates a rich selection of analog and digital peripherals that can interact without CPU intervention through the Programmable Peripheral Interconnect (PPI) system. A flexible 31-pin GPIO mapping scheme allows I/O like serial interfaces, PWM and quadrature demodulator to be mapped to any device pin as dictated by PCB requirements. This enables complete design flexibility associated with pin-out location and function.

## 2.11 Power modes

This product will have 3 different power modes:

Sleep Mode: All circuitry deactivated, except the SMPS and BLE module. Audio connection or audio streaming is activating the device. Activation Threshold audio level to be chosen/tested so no activation happens when unwanted high noise is present. On the other hand, threshold level to be chosen in such way that low input audio level is activating the system, so it doesn't stay in standby mode.

Standby Mode: all circuitry active but no audio processing/playing.

Play mode: all circuitry active and audio playing.

Power consumption table (mains measured, maximum rated power):

- excluding bulb socket consumption
- excluding accessory product consumption connected to inputs.

Mode	Max Consumption total system (Watt)
Sleep Mode	<0.5Watt
Standby Mode	<2Watt
Play Mode	<65Watt

When connected to mains, but no audio streaming, device goes into Sleep Mode after 20min for as long as there's no audio.

Device can be woken up from Sleep Mode:

- by inserting an Aux cable into the connector and wake-up will be based on audio level threshold settings. (level of the input).
- by BLE signal from remote App.

## 2.12 Power supply & Grounding

The Power supply is an internal open frame Type, based on SMPS technology.

This supply serves worldwide use and covers operating Input Voltage 90 till 264Vac. (47~ 63Hz).

The build-in Power supply is able to charge USB devices (according to USB standard) and Apple protectable devices except iPad.

It also need to be able to charge an optional external powerbank.

**Note ! : To avoid unwanted alien/digital noise through the audio channels, the whole system needs to carry total split power and audio grounding lines from the start of the SMPS. Any external accessory dongle connected to our analog or digital inputs shall NOT cause alien noise due to bad internal accessory grounding design. The design of the MAIN board need to make sure that no grounding loops can exist between several different audio inputs when connecting several accessories.**



## 2.13 Speakers

Acoustical architecture is based on:

- One 6 ½ inch subwoofer speaker 4 ohms 40Watt.
- Two 25mm midrange speakers 4 ohms 20W each.

## 3 Technical specifications

In this chapter, are only the technical specifications listed for commercial reasons.

### General test conditions:

- Channel loading 4 Ohm/channel (depending on the driver impedance).
- Typical input frequency:
  - 1kHz for Left and right Mid/high channel
  - 100 Hz for subwoofer channel(s)

### 3.1 Audio specifications.

#### 3.1.1 Input specs

##### Analogue input:

- Max. input: 2Vrms (Valid for Max volume setting)
- Nominal input: 500mVrms
- Input Sensitivity: **300mVrms**
  - Freq rang: see specification sheet from supplier
  - Responding with output power: see specification from supplier
- Input impedance: min 10k Ohm
- Detection level for wake up: **1mV** as target. Below this threshold amplifier will be muted.

##### Digital Input (USB-A):

Supported sample frequency.

- 32, 44.1, 48 kHz (Controller runs at 48kHz)
- This input has automatic (digital) audio detection.

#### 3.1.2 Output specs (amplifiers)

- Output power per channel
  - Left and right channel:
    - 2 x 20 Watt FTC at 1% THD (resistor loaded 4 ohm)
  - Subwoofer channel
    - 40 Watt FTC at 1% THD (resistor loaded 4 ohm)
- Signal to noise (SNR) (Volume @ max) :
  - Aux analogue: > 65 dBa (1kHz A-weighted)
  - Digital : >80 dBa (1kHz A-weighted)
- THD (Distortion @ 5 Watt output/1kHz) : Typ. < 1%
- Noise:
  - Standby noise; **Max 23 dB\_SPL**; Soundpower measured at a distance of 10 cm, in all relevant directions; Noise measurement. (Final figure to be verified)
  - "On" noise (mechanical noise); **Max 26 dB\_SPL**; Soundpower measured at a distance of 10 cm, in all relevant directions; Noise measurement.. (Final figure to be verified)
- Residual Noise in On-mode, Volume level 0: TBD : **300µV**

## 4 Functional requirements

### 4.1 User interface

This chapter describes control and behaviour for the set.

#### 4.1.1 Buttons and controls

The following control functions are available on the side & bottom of the product.

Control	Type	Function	number
Bass Control	Digital Rotary switch	Adjustable Bass Gain (270° rotation)	1
Volume Control	Digital Rotary switch	Volume up/down (>360° rotation)	1
Audio switch	Push button switch	Audio switch ON/OFF	1
Lamp switch	Push button switch	Light bulb switch ON/OFF	1
Hidden pin switch	Push button	For SW-version message, etc	1

#### 4.1.2 Visual indicators

- 1 Bi-color LED (red/green) for audio standby/on mode.
  - no color: no power
  - red color: sleep; if no audio for 20min, set goes in sleep
  - green color: power and audio streaming

#### 4.1.3 Audible sound indicators

To be discussed based on chosen system architecture and voice control chip.

### 4.2 Volume level and steps

Evaluation to be done with the **32 steps of digital volume**.  
Also, to be checked if volume increase is linear or not.

### 4.3 Software

To be checked what are the possibilities in the used MCU platform.  
MCU SW-upgrade and external Flash memory upgrade through USBA #1.  
Flow chart and Source code to be obtained from supplier.

### 4.4 Out of Factory settings.

- Bass control level: middle setting of the min-max settings
- Volume level: 50% volume control level
- Audio switch: OFF-position
- Lamp switch: OFF-position

#### 4.5 Normal Operating conditions/Climate conditions

- Temperature stability in line with regulations on indoor equipment.
- Humidity stability in line with regulations on indoor equipment.
- Altitude between 0 – 3000m.

Operating on SPEC	Range	Unit	condition
Temperature	+ 0 / + 40	°C	Working within Specification
Relative Humidity	20 – 90	%	

Operating (outside spec)	Range	Unit	condition
Temperature	-10/ + 60	°C	Audio working
Relative Humidity	20 – 90	%	

Storage(non-operating)	Range	Unit	condition
Temperature	- 20 / + 60	°C	Working within Spec after storage and 1 hour acclimatization
Relative Humidity	95	%	

All above mentioned complies with the nominal output power.

#### 4.6 Environmental Requirements

Set will be in line with following environmental requirements

- RoHS & China RoHS
- WEEE
- ~~Grüne Punkt~~

#### 4.7 Firmware Update

Via control panel USB-A socket to MCU.

#### 4.8 Service documentation

- All schematics, layout (Gerbers), component location files, Partslists
- SW source codes of MCU and DSP.

#### 4.9 APP design

- Control of general Audio settings like Classic, Jazz, Pop, Rock.
- Control of Volume
- Control of Sound messages
- Readback of device info (serial number, model, power, etc)
- Adjustment of filter settings inside the DSP core.

**APP User interface MMI to be discussed.**

-----