

REVISION RECORD			
LTR	ECO NO:	APPROVED:	DATE:

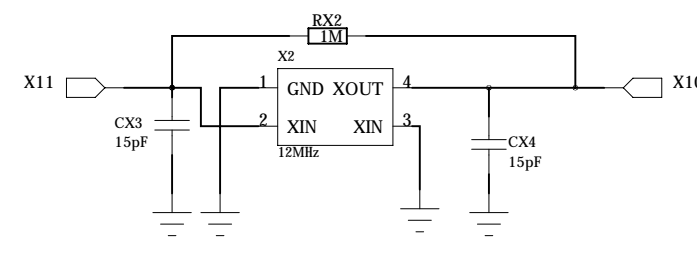
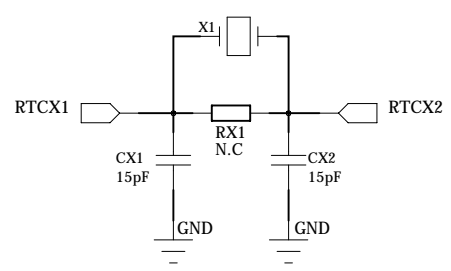
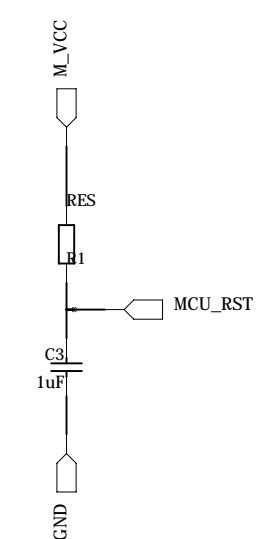
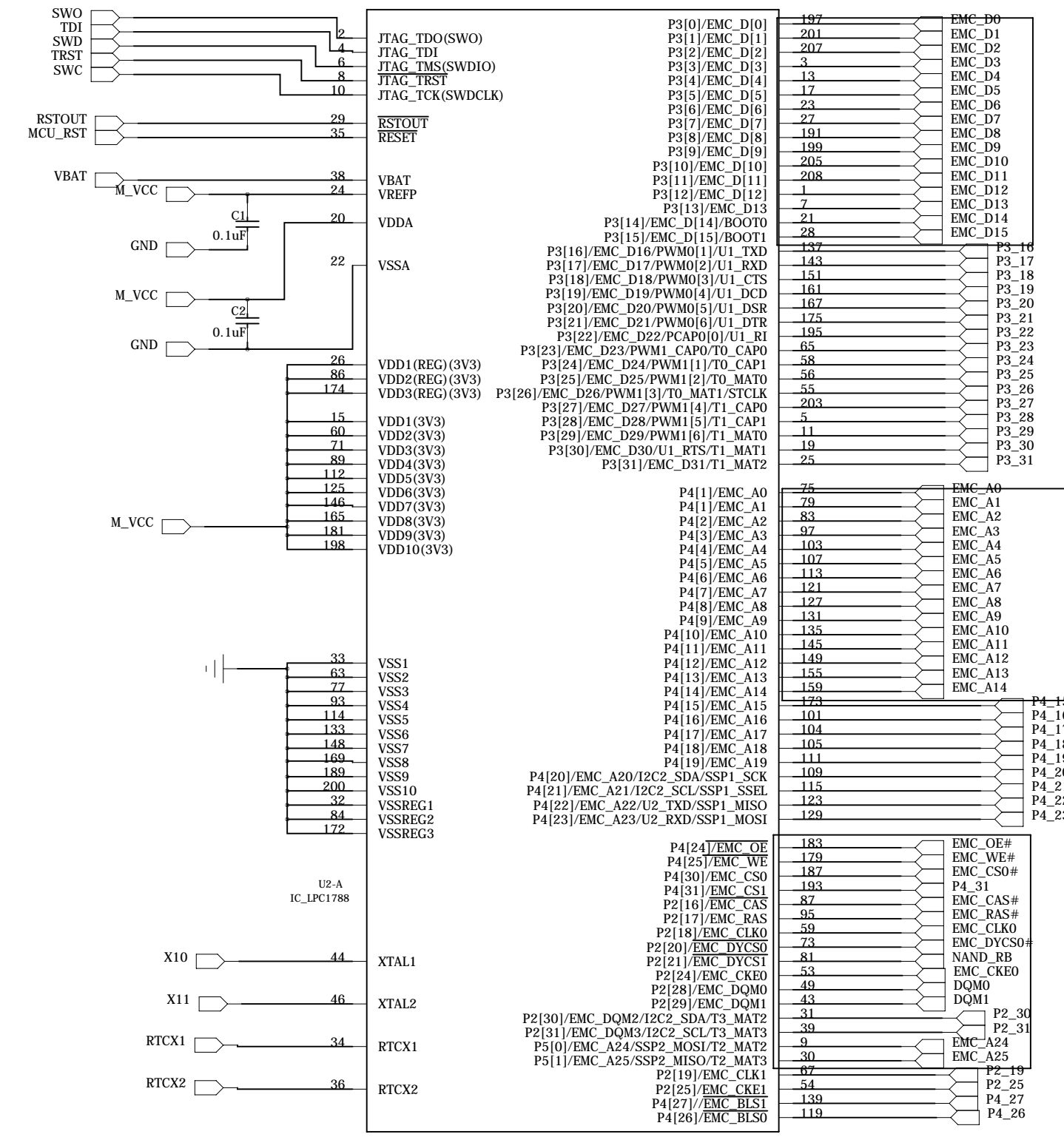

COMPANY: <Company Name>

TITLE: <Title>

DRAWN: <Drawn By>	DATED: <Drawn Date>	CODE:	SIZE:	DRAWING NO:	REV:
CHECKED: <Checked By>	DATED: <Checked Date>				
QUALITY CONTROL: <QC By>	DATED: <QC Date>	<Code> A2<Drawing Number>Revision>			
RELEASED: <Released By>	DATED: <Release Date>				

SCALE: <Scale>

SHEET: 1 OF 5

D

C

B

A

D

C

B

A

REVISION RECORD			
LTR	ECO NO:	APPROVED:	DATE:

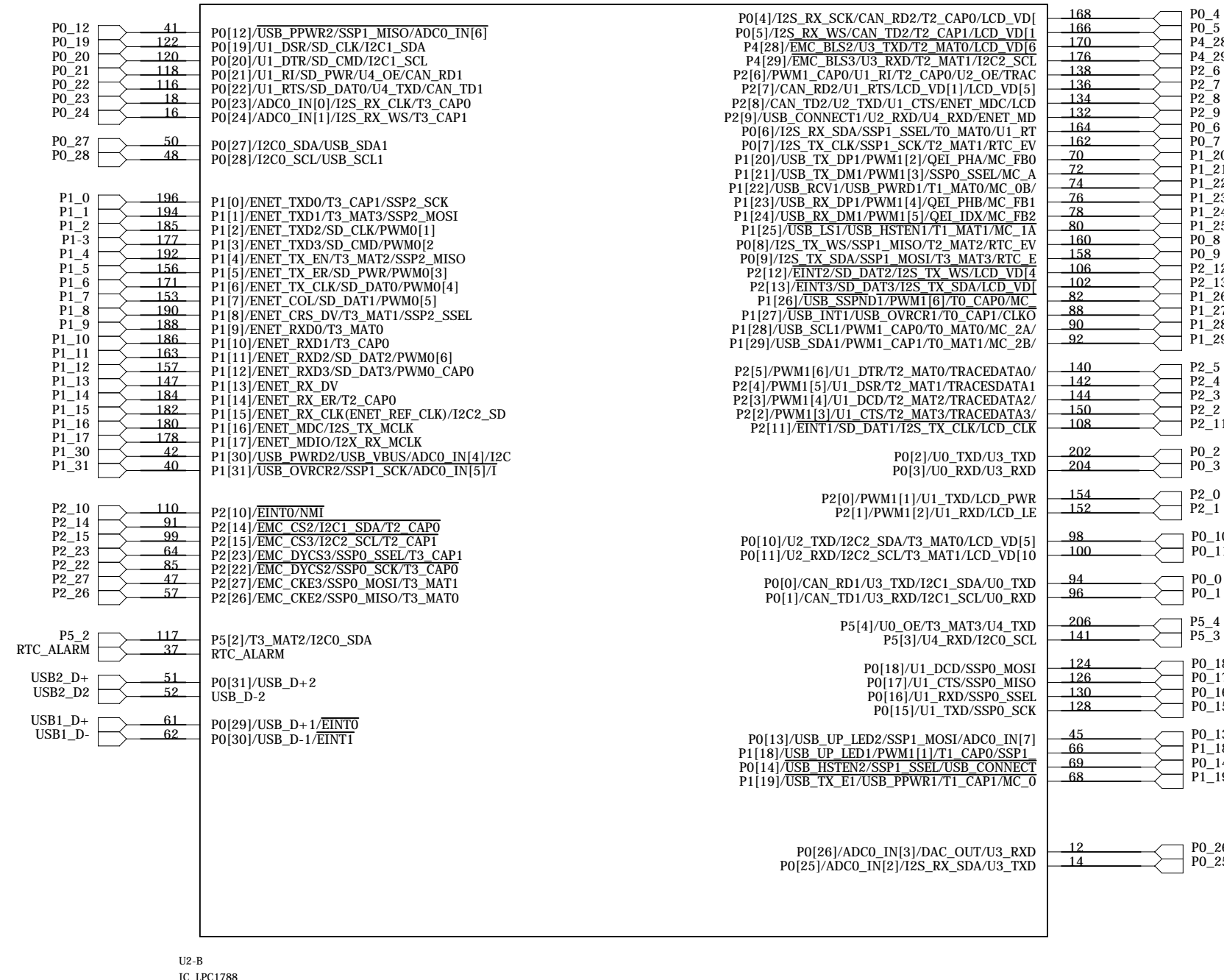

COMPANY: <Company Name>			
TITLE: <Title>			
DRAWN: <Drawn By>	DATED: <Drawn Date>		
CHECKED: <Checked By>	DATED: <Checked Date>	CODE: <Code>	SIZE: A2
QUALITY CONTROL: <QC By>	DATED: <QC Date>	DRAWING NO: <Drawing Number>	
RELEASED: <Released By>	DATED: <Release Date>	SCALE: <Scale>	REV: <Revision>
SHEET: 2 OF 5			

REVISION RECORD			
LTR	ECO NO:	APPROVED:	DATE:

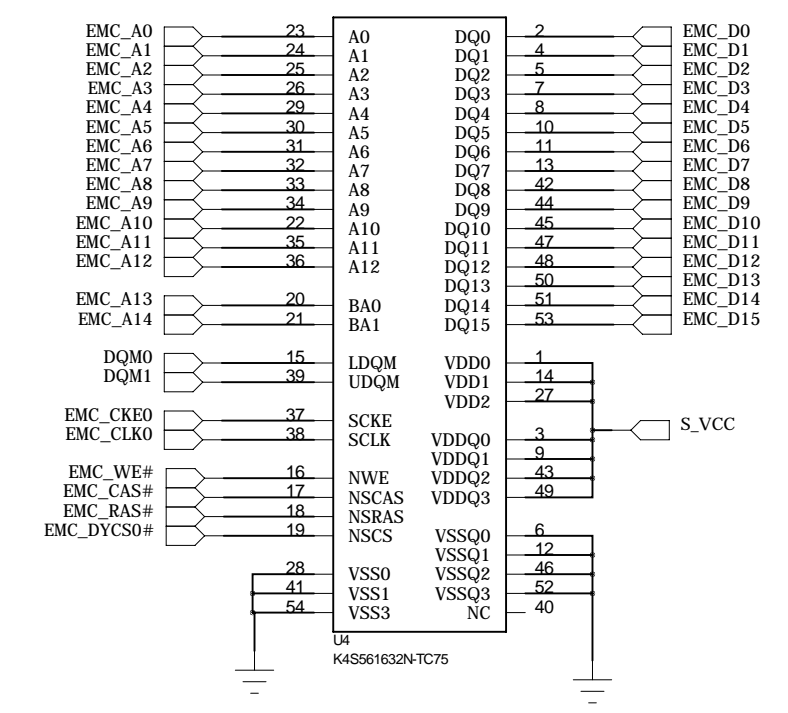
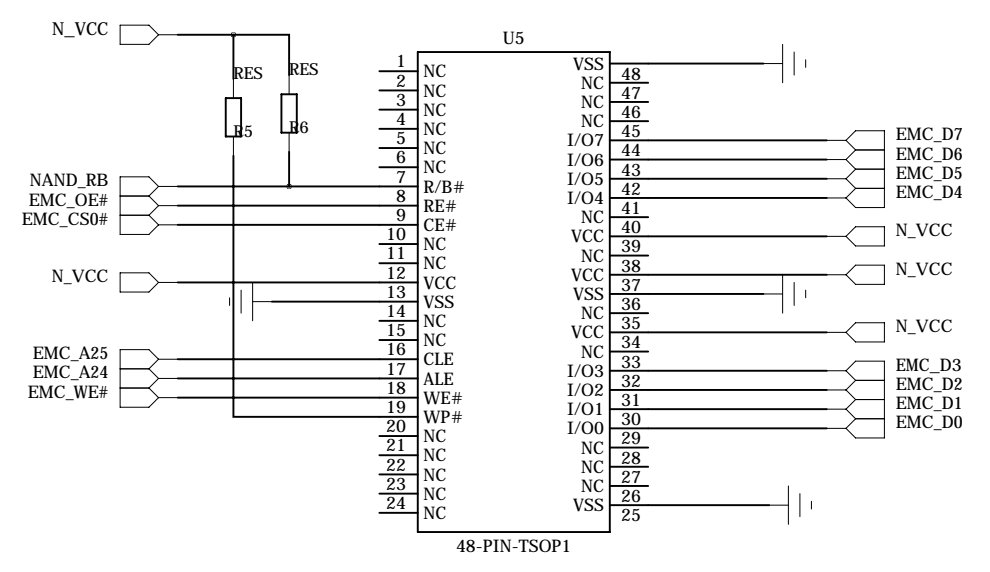
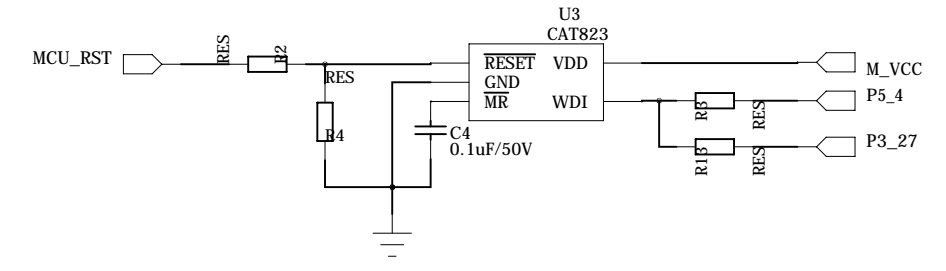

COMPANY: <Company Name>

TITLE: <Title>

DRAWN: <Drawn By>	DATED: <Drawn Date>
CHECKED: <Checked By>	DATED: <Checked Date>
QUALITY CONTROL: <QC By>	DATED: <QC Date>
RELEASED: <Released By>	DATED: <Release Date>

CODE:	SIZE:	DRAWING NO:	REV:
<Code>	A2	<Drawing Number>	<Revision>
SCALE: <Scale>			SHEET: 3 OF 5

6

5

4

3

2

1

REVISION RECORD			
LTR	ECO NO:	APPROVED:	DATE:

D

D

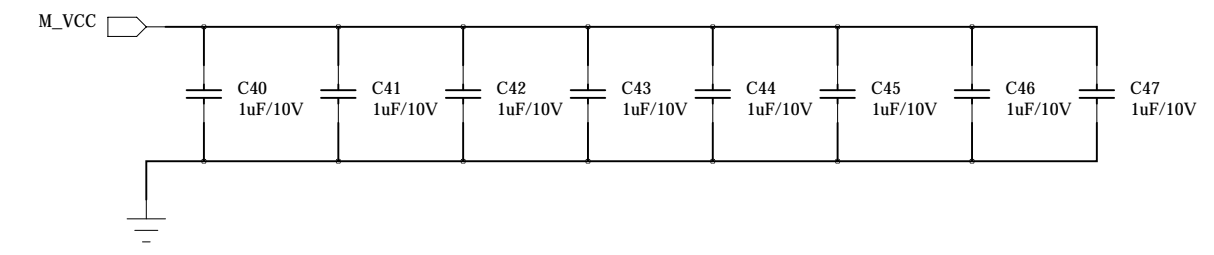

MCU_VCC FILWER

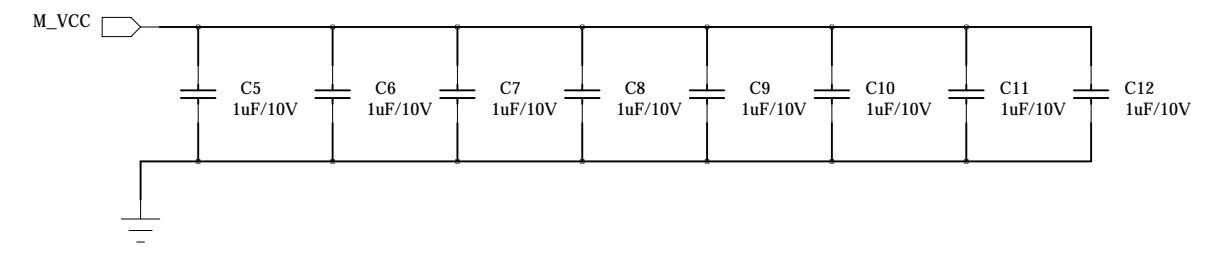

NAND_VCC FILWER

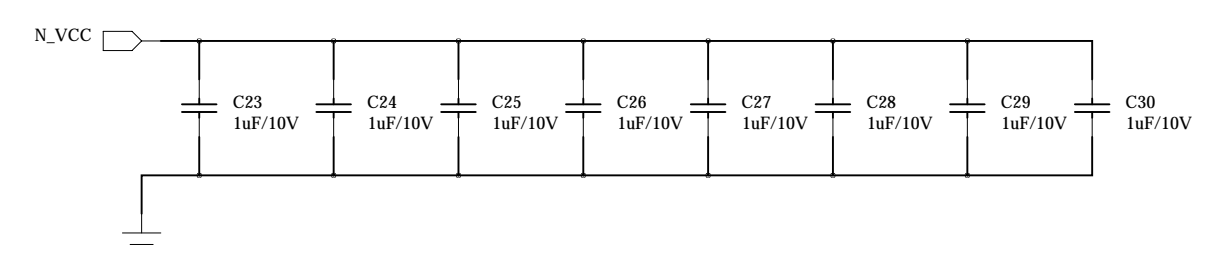

SDRAM_VCC FILWER

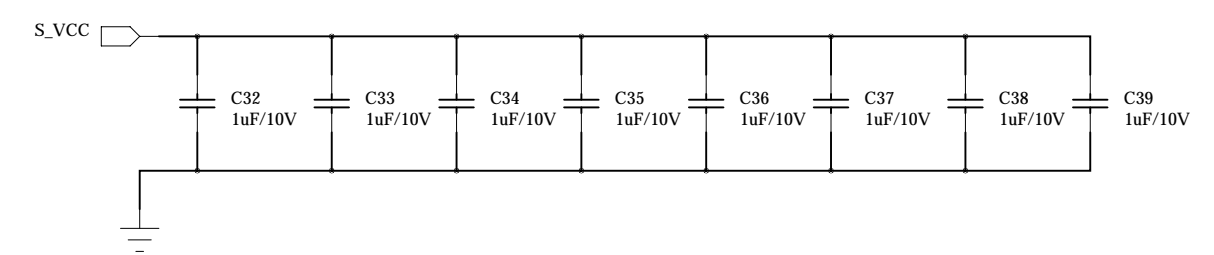

C

C

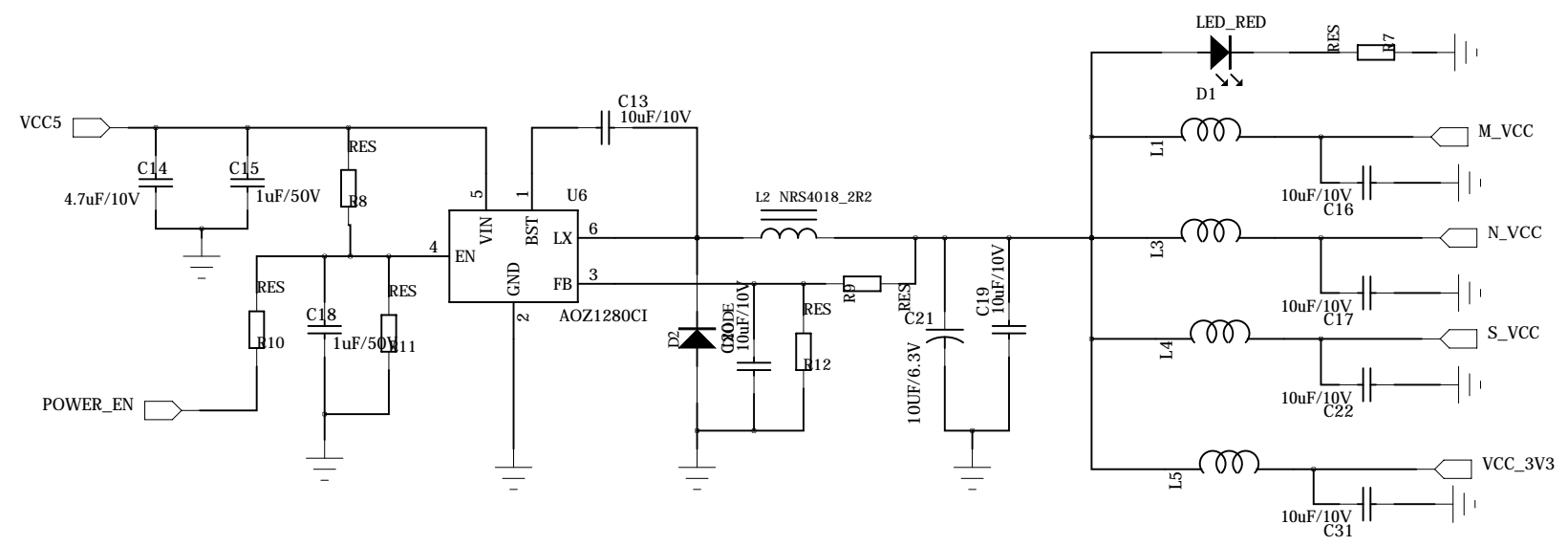

B

B

A

A

COMPANY: <Company Name>

TITLE: <Title>

DRAWN: <Drawn By>	DATED: <Drawn Date>
CHECKED: <Checked By>	DATED: <Checked Date>
QUALITY CONTROL: <QC By>	DATED: <QC Date>
RELEASED: <Released By>	DATED: <Release Date>

CODE:	SIZE:	DRAWING NO:	REV:
<Code>	A2	<Drawing Number>	<Revision>

6

5

4

3

2

1

REVISION RECORD			
LTR	ECO NO:	APPROVED:	DATE:

D

D

C

C

B

B

A

A

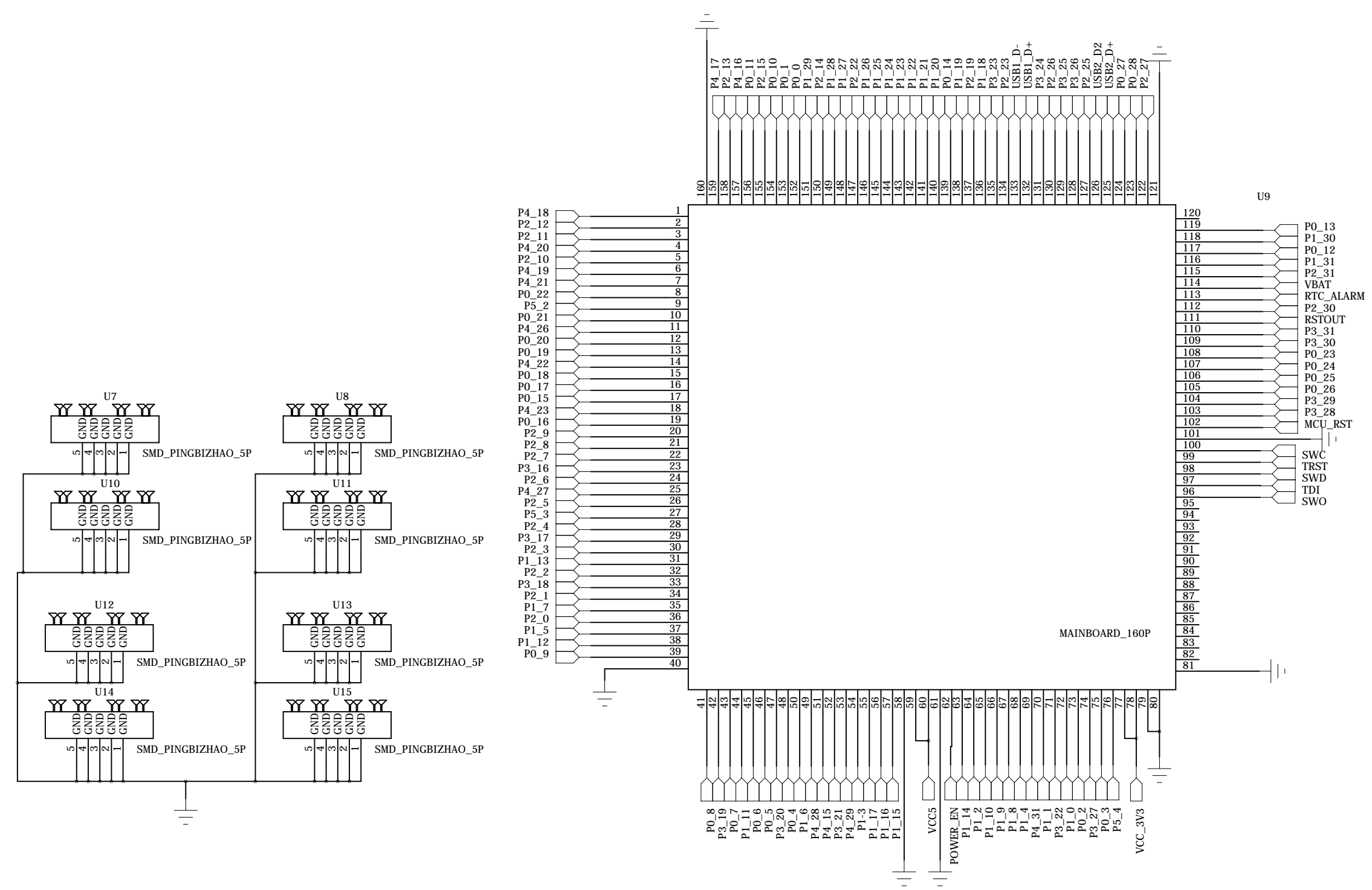

COMPANY: <Company Name>			
TITLE: <Title>			
DRAWN: <Drawn By>	DATED: <Drawn Date>	CODE: <Code>	
CHECKED: <Checked By>	DATED: <Checked Date>	SIZE: A2	DRAWING NO: <Drawing Number>
QUALITY CONTROL: <QC By>	DATED: <QC Date>	REV: <Revision>	
RELEASED: <Released By>	DATED: <Release Date>	SCALE: <Scale>	SHEET: 5 OF 5