

Stellaris® AC Induction Motor Reference Design Kit

User's Manual



Copyright

Copyright © 2007–2009 Texas Instruments, Inc. All rights reserved. Stellaris and StellarisWare are registered trademarks of Texas Instruments. ARM and Thumb are registered trademarks, and Cortex is a trademark of ARM Limited. Other names and brands may be claimed as the property of others.

Texas Instruments
108 Wild Basin, Suite 350
Austin, TX 78746
Main: +1-512-279-8800
Fax: +1-512-279-8879
<http://www.luminarymicro.com>



Table of Contents

Chapter 1: Stellaris® AC Induction Motor Reference Design Kit Overview	11
Safety Information.....	11
Using the RDK.....	11
Features.....	12
Motor Technology.....	12
Introduction to AC Induction Motors.....	12
AC Induction Motor Types.....	13
Variable Speed.....	14
RDK Specifications.....	15
Electrical.....	15
Mechanical.....	15
Capabilities.....	15
Chapter 2: Graphical User Interface	17
Main GUI Window.....	17
File Menu.....	20
Parameter Configuration Window.....	21
PWM Configuration.....	21
Motor Configuration.....	22
Drive Configuration.....	23
DC Bus Configuration.....	24
Chapter 3: Hardware Description	27
System Description.....	27
Block Diagram.....	28
Functional Description.....	28
Microcontroller (Schematic Pages 1-2).....	29
Output Power Stage (Schematic Page 3).....	29
Isolated Control Interfaces (Schematic Page 4).....	30
Power Supplies (Schematic Page 5).....	31
Isolated JTAG Interface (Schematic Page 6).....	31
Software.....	31
Modulation Methods.....	32
Other Functions.....	32
Motor Control Parameters.....	32
Parameter Reference.....	32
Implementation Considerations.....	33
Motor Selection.....	33
Bus Capacitors.....	33
Heat Sinking.....	33
Power Line Filtering.....	33
Serial Protocol.....	33
Appendix A: Parameters and Real-Time Data Items	35
Parameters.....	35
Parameter Descriptions.....	37

Informational Parameters.....	37
Firmware Version	37
Motor Drive Status	38
Motor Drive Fault Status	38
Motor Configuration Parameters.....	39
Motor Type.....	39
Number of Poles	39
Encoder Present	39
Number of Encoder Lines	39
V/f Table Range Select	40
V/f Table.....	40
Minimum Drive Frequency	40
Maximum Drive Frequency	41
Minimum Motor Current	41
Maximum Motor Current	41
PWM Configuration Parameters	42
PWM Frequency	42
PWM Dead Time.....	42
Waveform Update Rate	42
Minimum PWM Pulse Width	43
High-side Gate Driver Precharge Time.....	43
Motor Drive Configuration Parameters	43
Modulation Type	43
Motor Drive Direction	44
Acceleration Rate.....	44
Deceleration Rate	44
Target Drive Frequency	45
Current Drive Frequency.....	45
Dynamic Braking Configuration Parameters.....	45
Dynamic Braking Enable.....	45
Dynamic Brake Engage Voltage	45
Dynamic Brake Disengage Voltage	46
Maximum Dynamic Braking Time	46
Dynamic Brake Cooling Time	46
DC Injection Braking Configuration Parameters	47
DC Injection Braking Enable	47
DC Injection Braking Voltage	47
DC Injection Braking Time	47
Closed-Loop Configuration Parameters.....	47
Closed-Loop Mode Enable	47
Frequency Controller P Coefficient	48
Frequency Controller I Coefficient	48
DC Bus Configuration Parameters.....	48
Minimum DC Bus Voltage	48
Maximum DC Bus Voltage.....	49
DC Bus Voltage Compensation Enable	49
DC Bus Deceleration Voltage	49
Miscellaneous Parameters.....	50

On-board User Interface Enable	50
Maximum Ambient Temperature	50
Real-Time Data Items	50
Real-Time Data Items Descriptions	51
Drive Status Parameters	51
Motor Drive Status	51
Motor Drive Fault Status	51
Processor Usage	52
Motor Speed Parameters	52
Current Stator Frequency	52
Current Rotor Frequency	52
Measurement Parameters	52
DC Bus Voltage	52
Motor Phase U Current	53
Motor Phase V Current	53
Motor Phase W Current	53
Motor Current	53
Ambient Temperature	53
Appendix B: Schematics	55
Appendix C: PCB Component Locations	63
Appendix D: Bill of Materials (BOM)	65

List of Tables

Table 2-1. Description of GUI Main Window Controls	17
Table 2-2. Description of PWM Configuration Controls	21
Table 2-3. Description of Motor Configuration Controls	22
Table 2-4. Description of Drive Configuration Controls	24
Table 2-5. Description of DC Bus Configuration Controls	25
Table 3-1. Current Monitoring Circuits.....	30
Table 3-2. Control Interface Functions	30
Table A-1. Parameter Configuration Summary	35
Table A-2. Real-Time Data Items	50

List of Figures

Figure 1-1. AC Induction Motor.....	13
Figure 1-2. Typical Blower Incorporating a Single-Phase PSC Motor	14
Figure 1-3. Linear V/f Curve for a 340 Hz Motor.....	14
Figure 2-1. AC Induction Motor Main GUI Window.....	17
Figure 2-2. PWM Configuration Window	21
Figure 2-3. Motor Configuration Window	22
Figure 2-4. Drive Configuration Window	23
Figure 2-5. DC Bus Configuration Window.....	25
Figure 3-1. Block Diagram	28

Stellaris® AC Induction Motor Reference Design Kit Overview

Reference Design Kits (RDKs) accelerate product development by providing ready-to-run hardware, a typical motor and comprehensive documentation including hardware design files. Designers without prior motor control experience can successfully implement a sophisticated motor control system using the AC Induction Motor RDK.

Safety Information

WARNING – Risk of Electric Shock

The microcontroller in the RDK is not referenced to ground; it is at AC line potential. Do not make direct connection to the JTAG header or any other microcontroller-related circuit. Read the Quickstart Guide first for additional warnings.

This RDK operates from AC line voltage. Improper use or application carries electric shock, fire, and other risks that may result in serious injury or death. Please read and follow these safety notices:

- This documentation and kit must only be used by people with training and experience in working with voltage potentials up to 230 V.
- The control board has both high-voltage potential and safety low-voltage sections.
- Do not connect high-voltage potential circuits to safety low-voltage circuits or to ground-referenced equipment such as computers or test equipment.
- After power is removed, high voltages remain until the bus capacitors discharge. Wait at least one minute after removing power before working with high-voltage circuitry.
- Use caution when using the on-board controls to adjust motor speed etc. High-voltage circuits are in close proximity.
- Never perform work on the control board, motor or, wiring while power is applied. Always wear eye protection and use care when operating the motor.

In addition to safety risks, other factors that may damage the control hardware, the motor, and its load include improper configuration, wiring, or software. Minimize the risk of damage by following these guidelines.

Using the RDK

The recommended steps for using the RDK are:

- **Follow the Quickstart Guide included in the kit.** The Quickstart guide will help you get the motor up and running in minutes. It also contains important safety information that should be read before using the RDK.

- **Use the RDK GUI software to evaluate and optimize motor performance.** The RDK GUI gives real-time access to over 30 operating parameters. Parameters and data transfer between the control and PC over a USB cable.
- **Customize and integrate the hardware and software to suit an end application.** This User's Manual and the Software Reference Manual are two important references for completing your project. Software can be programmed in the motor control board using either the RDK GUI software or using a JTAG debug interface (available from leading development tools vendors).

Features

- Advanced motor control for three-phase and single-phase AC induction motors
- Flexible platform accelerates integration process
- Easily change line filter, bus capacitors, and JTAG interface
- Compatible with all main control algorithms including space vector modulation and sine control
- Split low-side current sensing for accurate current sensing
- Dynamic braking circuit
- Active in-rush control circuit
- Several isolated control input options including:
 - Integrated USB port (Virtual COM port)
 - Windows GUI application for configuration, control, and monitoring
 - Logic-level serial port
 - Speed potentiometer and mode switch
 - Quadrature encoder/tachometer input for speed and position monitoring
- Electrically isolated JTAG port for software debugging
- Bootloader for firmware upgrades over USB
- Integrated AC Line Filter

Motor Technology

Introduction to AC Induction Motors

The ACIM RDK controls a class of motors known as Alternating Current (AC) induction motors. AC induction motors are accurately described as the work horses of industry. In addition, AC induction motors are widely found throughout the home in applications such as heating and air conditioning systems, ceiling fans, and appliances.

Inside the AC induction motor, the applied AC voltage creates a sinusoidal current in the stator winding. The stator does not move, but its coil or coils are positioned to create a rotating electromagnetic field. The AC induction motor contains no permanent magnets. Instead, the stator field induces a current in the rotor; hence the term induction. The current in the rotor creates its own electromagnetic field. The coupling of the rotor and stator fields creates mechanical motion in the motor.

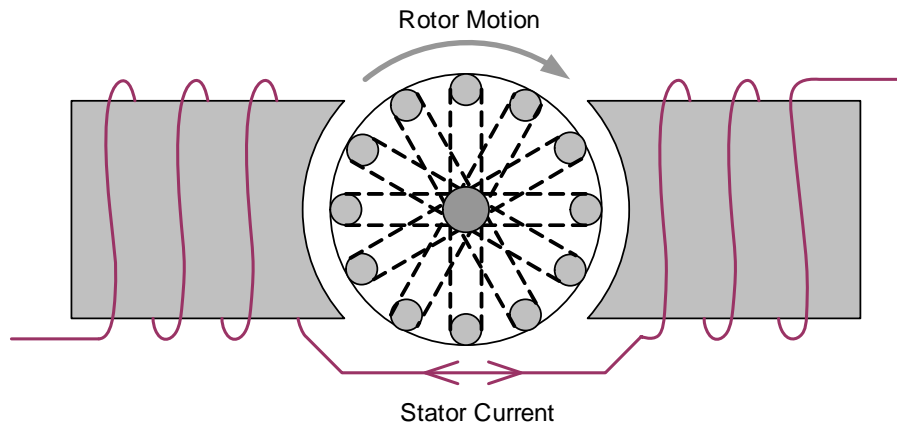
Figure 1-1. AC Induction Motor

The speed of the motor is, therefore, primarily controlled by the frequency of the AC current in the stator and the also the number of poles intrinsic in the motor design. This can be expressed as the following equation:

$$\text{Synchronous Speed} = 120 * \text{Frequency} / \text{Number of Poles}$$

As the rotor is loaded (note that some inherent load is always present), the motor must produce torque. Torque requires that the rotor turns more slowly than the stator field. The difference in speed is known as slip. For example, a typical motor with a synchronous speed of 3600 rpm may have a shaft speed of 3350 rpm at full load.

The motor included in the RDK is made by ATB Selni for laundry appliances. The nameplate frequency range is 0-340 Hz and the motor has two poles, so the synchronous speed range is 0-20400 rpm. This motor is capable of very high speeds.

The RDK controls motor speed by varying the frequency of the current in the stator coil. There are several different voltage modulation techniques, but all are designed to result in sinusoidal stator current.

AC Induction Motor Types

There are numerous variations within the class of AC induction motors. Possibly the most notable classification is the number of phases. The ACIM RDK is a variable frequency motor control that can operate both single-phase and three-phase motors. Three-phase motors are most commonly used with variable frequency controls as they offer greater efficiency, higher torque, and wider speed range than their single-phase counterparts.

There are many variations of single-phase AC induction motors, but only two types are candidates for variable frequency control. Both permanent-split-capacitor (PSC) and shaded-pole motors can be used with this RDK as they have no internal switching mechanism.

Figure 1-2. Typical Blower Incorporating a Single-Phase PSC Motor



Variable Speed

Reducing voltage to increase slip is not an effective method of speed control as the torque drops considerably. Varying frequency is far more effective, but there are additional considerations. As the frequency decreases, the effective impedance of the motor decreases proportionately. To maintain constant current and torque, the RDK reduces voltage using a transfer function known as a V/f curve. The RDK allows this to be customized for a specific motor or application. Figure 1-3 shows a linear V/f curve for a 340 Hz motor. Note that the voltage ramps with the frequency until it hits the motor's nominal operating frequency.

Figure 1-3. Linear V/f Curve for a 340 Hz Motor

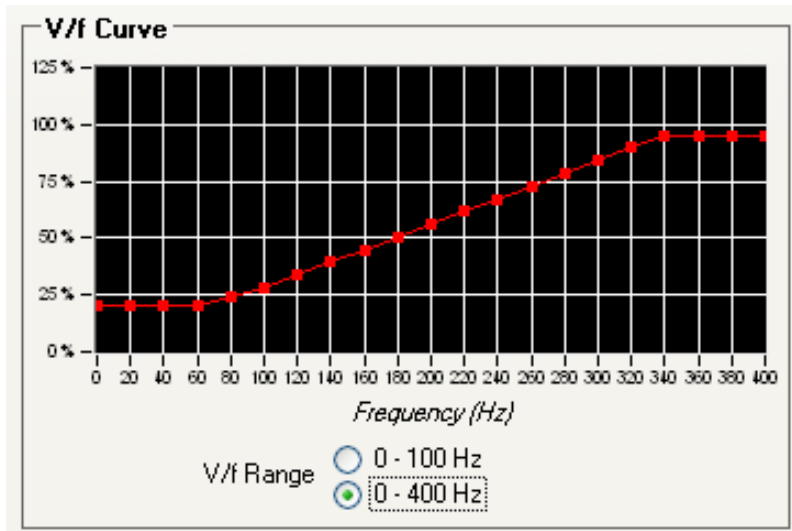

RDK Specifications

This reference design meets the following specifications. The RDK has been engineered to simplify scaling to other current or voltage requirements.

Electrical

- Dual supply voltages (plug selectable)
 - 230 V_{AC} ±15% 1 phase
 - 115 V_{AC} ±15% 1 phase (up to ½ HP only)
- Supply current: 10 A_{RMS} (max)
- Continuous output current: 3.2 A_{RMS}
- Electrical isolation: 2500 V_{RMS}

Mechanical

- PCB size: 3.7" x 4.5" (92 mm x 115 mm)
- Overall size: 5.25" x 6.75" x 1.3" (134 mm x 172 mm x 34 mm)

Capabilities

- Frequency range: 0-400 Hz in 0.1 Hz steps
- PWM frequency: Selectable 8, 12.5, 16, and 20 kHz

Graphical User Interface

This section describes the GUI interface in detail.

Main GUI Window

Motor operation is controlled from the main window (see Figure 2-1). The main window provides user controls for controlling the motor, as well as several indicators to provide status of the motor operation. Most parameters can only be modified when the motor is stopped, and are not selectable while the motor is running. Table 2-1 describes the controls in detail.

Figure 2-1. AC Induction Motor Main GUI Window

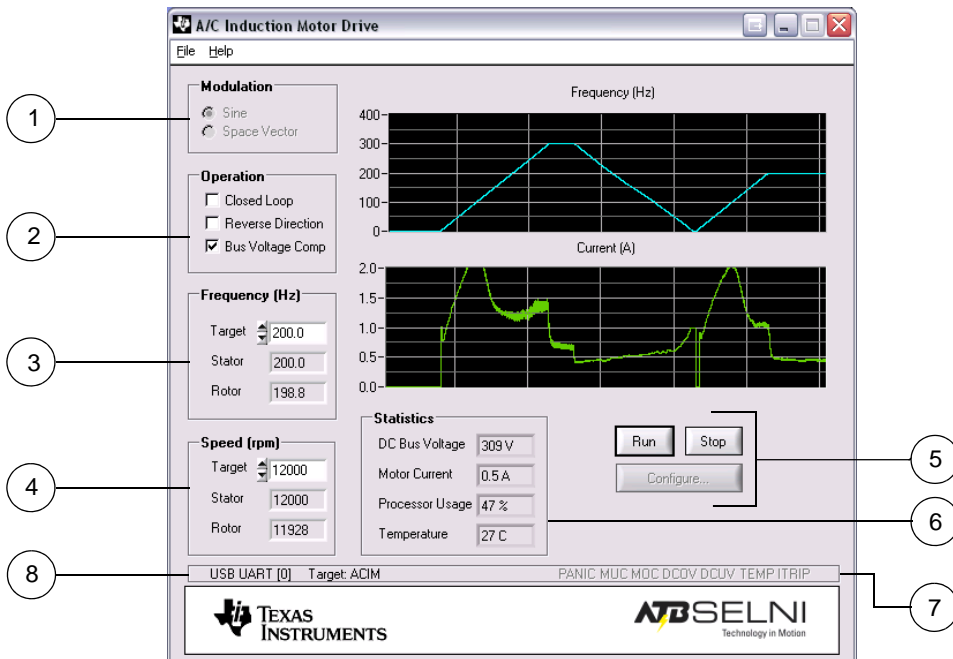

Table 2-1. Description of GUI Main Window Controls

Item No.	Name	Description
1	Modulation Area	
	Sine	Sets the modulation type to sine.
	Space Vector	Sets the modulation type to space vector.

Table 2-1. Description of GUI Main Window Controls (Continued)

Item No.	Name	Description
2	Operation Area	
	Closed-Loop mode	Selects between Open-Loop mode and Closed-Loop mode. This is only available for motors that have an encoder or tachogenerator for feedback of the rotor speed (motors without rotor speed feedback can only be run in Open-Loop mode).
	Reverse Direction	Selects the direction of rotation. This is not available for single-phase motors.
	Bus Voltage Comp	Enables bus voltage compensation. This improves the drive waveforms by reducing the voltage ripple seen by the motor.
3	Frequency Area	
	Target	Sets the frequency at which the motor runs. In Open-Loop mode, this is the frequency applied to the motor. In Closed-Loop mode, this setting is the rotor frequency (that is, the tach sensor allows the drive to compensate continuously for slip). The desired frequency can be typed into the box. If the motor is already running, it will change frequency to match.
	Stator	Shows the rotational frequency of the stator field (that is, the field in the fixed part of the motor). In Open-Loop mode, this matches the target frequency. In Closed-Loop mode, the stator frequency is higher than the target frequency as the PI control loop compensates for slip in the motor.
	Rotor	Shows the rotational frequency of the rotor. This field is not user-editable. In Open-Loop mode, this is lower than the target frequency due to slip in the motor. In Closed-Loop mode, this matches the target frequency.
4	Speed (rpm) Area	
	Target Speed (rpm)	Displays the motor speed in revolutions per minute (rpm). There is a direct correlation between this value and the target frequency value. In Open-Loop mode, this is the speed of the stator field. In Closed-Loop mode, this is the actual shaft speed.
	Stator Speed (rpm)	Displays the rotational speed of the stator field in revolutions per minute. This field is not user-editable. In Open-Loop mode, this matches the target speed. In Closed-Loop mode, the stator speed is higher than the target frequency as the PI control loop compensates for slip in the motor.
	Rotor	Displays the rotational speed of the rotor in revolutions per minute. This field is not user-editable. In Open-Loop mode, this will be lower than the target speed due to slip in the motor. In Closed-Loop mode, this matches the Target Speed.

Table 2-1. Description of GUI Main Window Controls (Continued)

Item No.	Name	Description
5	GUI Main Window Buttons	
	Run button	Starts the motor. The motor runs using the current configuration until the Stop button is clicked or a fault condition is detected.
	Stop button	Stops the motor. If the motor is running, the motor decelerates to a stop. Once the Stop button has been clicked, the Run button must be clicked before the motor will operate again.
	Configure button	Opens the Parameter Configuration window. The Parameter Configuration window is described in more detail in "Parameter Configuration Window" on page 21.
6	Statistics Area	
	DC Bus Voltage	Indicates the average DC bus voltage. As the RDK sends more power to the motor, the ripple voltage increases and the DC bus voltage drops.
	Motor Current	Indicates the AC root-mean-square (rms) motor current as measured by the RDK control board.
	Processor Usage	Indicates the microcontroller CPU load by percentage. Useful for estimating the loading of different applications and motor control algorithms.
	Temperature	Indicates the ambient temperature near the microcontroller using the internal temperature sensor.
7	Indicator Area	
	Panic	Indicates that control has received a request to immediately shut-down without a controlled motor ramp down.
	Motor Under Current Fault (MUC)	Indicates that the motor was drawing less current than the under-current limit and the motor has been stopped. This feature is useful for detecting an open circuit in the motor. Some motors have internal thermal cut-outs, that can be detected with the MUC indicator.
	Motor Over Current Fault (MOC)	Indicates that the motor was drawing more current than the over-current limit and the motor has been stopped. This may indicated a motor stall condition.
	DC Over Voltage Fault (DCOV)	Indicates that the high-voltage DC supply rail is too high. This can occur if the motor is slowed down too quickly.
	DC Under Voltage Fault (DCUV)	Indicates that the high-voltage DC supply rail is too low. This can occur if the AC line voltage is out of specification.
	Over Temperature Fault (TEMP)	The ambient air temperature near the microcontroller has exceeded the limit and the motor has been stopped.
	Power	The power module has detected a massive overcurrent condition or a supply voltage problem and has shut-down. This can be due to a problem with the motor wiring or the motor itself.

Table 2-1. Description of GUI Main Window Controls (Continued)

Item No.	Name	Description
8	Special Indicator Area	
	COM Port	Displays the COM port number, and status. If the indicator is shown in black, and has a number shown for the COM port, then the serial port is opened. If the indicator is shown in red, and shows "Err", then no COM port is opened. The COM port selection dialog box can be opened by double clicking on the COM port indicator.
	Target	Displays the status of the target connection. If the "Target" is shown in black, and indicates "ACIM" then the program is communicating with the RDK via the USB/serial port. If the indicator is shown in red, then there was a problem communicating with the target. Communication with the target can be restarted by double clicking on the Target indicator.

File Menu

The File menu can be used to help manage the parameters. The following menu items are available:

- **Load Parameters from Flash:** The adjustable parameters that control the motor operation may be stored in flash memory in the RDK microcontroller. This menu choice commands the target to copy the parameters that were found in flash into the active memory. The parameters will only be loaded from flash if the motor is stopped. If the parameters are loaded from flash, then the values shown on the main and configuration windows will change to reflect the new parameter values.
- **Save Parameters to Flash:** Saves the adjustable motor parameters to the RDK microcontroller's flash memory. The parameters are only saved when the motor is stopped. If a valid set of parameters have been saved to flash, those will be loaded whenever the target is powered or reset.
- **Load Parameters from File:** The adjustable motor parameters can be loaded from a file that was previously saved. This menu choice will read the parameters from the file (if available) and send them to the target. The parameters will only be loaded if the motor is stopped.
- **Save Parameters to File:** The adjustable motor parameters can be saved to a file. Selecting this menu choice will cause all of the parameters to be read from the RDK board, and stored to a file. The parameters can only be stored to a file if the motor is stopped.
- **Update Firmware:** This menu choice can be used to load new firmware onto the RDK target board. A file chooser dialog box will open to allow the user to select the firmware binary file to load to the target. This menu choice can only be used if the motor is stopped. Once a file is chosen, the new firmware file will be sent to the RDK, the RDK will update the flash with the new program, and then restart.

NOTE: To restore the default parameters that came with your kit, from the File menu, select Load Parameters from File and load the selni.ini parameter file to the target. Then select Save Parameters to Flash from the File menu to save the default parameters into flash memory.

Parameter Configuration Window

The Parameter Configuration window is used to allow adjustment of certain system parameters. The window contains four tabs: PWM Configuration, Motor Configuration, Drive Configuration, and DC Bus Configuration. Open the Parameter Configuration window by clicking the Configure button on the main window and then clicking the tab you want to configure. The left and right arrows to the right of the tabs can be used to scroll to the tabs that are not visible.

Change the parameters and click the OK button to send the new parameters to the target. Click the Cancel button to discard any changes.

PWM Configuration

In the Parameter Configuration window, click the PWM Configuration tab to display parameters for configuring the PWM output (see Figure 2-3). Table 2-3 describes the controls in detail.

Figure 2-2. PWM Configuration Window

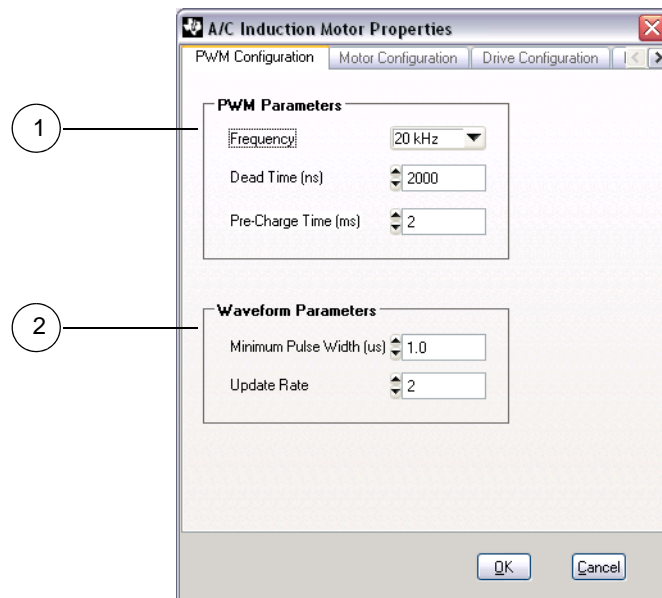

Table 2-2. Description of PWM Configuration Controls

Item No.	Name	Description
1	PWM Parameters	
	Frequency	Sets the frequency of the PWM waveforms produced by the microcontroller. Higher frequencies will produce less audible noise in the motor but result in higher processor usage.
	Dead Time	The amount of time between the activation of the high and low side switches on a motor phase. This is used to prevent a short-circuit.
	Pre-Charge Time	The amount of time to pre-charge the high-side gate drivers before starting the motor drive.

Table 2-2. Description of PWM Configuration Controls (Continued)

Item No.	Name	Description
2	Waveform Parameters	
	Minimum Pulse Width	The width of the smallest pulse (positive or negative) that should be produced by the motor drive. This prevents pulses that are too short to perform any useful work (but that still incur switching losses).
	Update Rate	The number of PWM periods between updates the output waveforms. Updating the output waveform more frequently results in better quality waveforms (and less harmonic distortion) at the cost of higher processor usage.

Motor Configuration

In the Parameter Configuration window, click the Motor Configuration tab to display parameters for configuring the motor (see Figure 2-3). Table 2-3 describes the controls in detail.

Figure 2-3. Motor Configuration Window

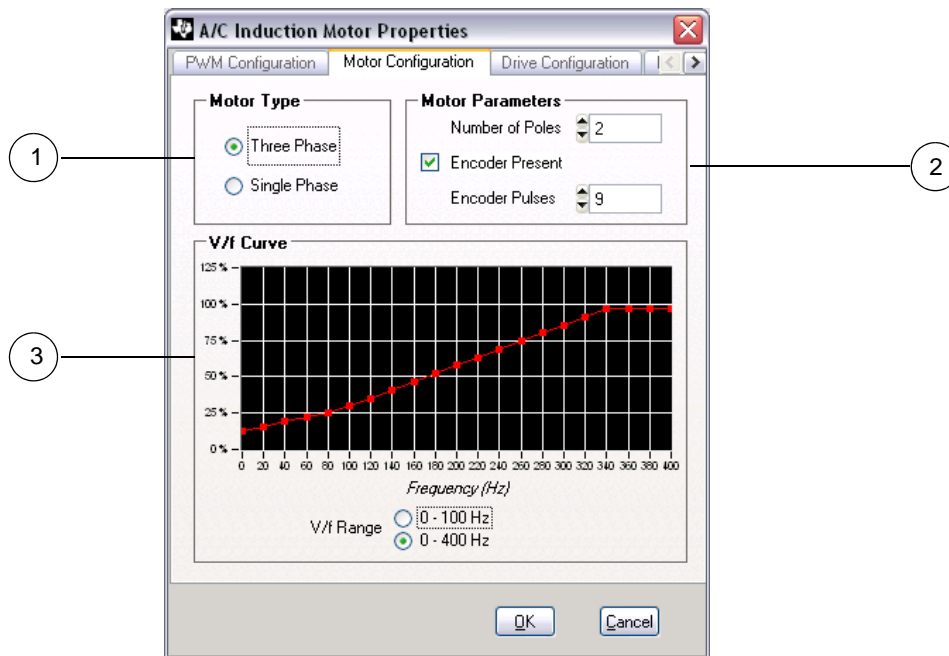

Table 2-3. Description of Motor Configuration Controls

Item No.	Name	Description
1	Motor Type	
	Three Phase	Sets the motor type to three phase for motors such as the ATB Selni motor included in the kit. Use this setting for the motor included in the ACIM RDK.
	Single Phase	Sets the single phase setting which creates a single phase output from the control board to U and V motor terminals.

Table 2-3. Description of Motor Configuration Controls (Continued)

Item No.	Name	Description
2	Motor Configuration	
	Number of Poles	Used by the RDK to convert frequency (Hz) to rpm.
	Encoder Present	Check this box if an Encoder or Tach is present.
	Encoder Pulses	Number of pulses in each motor shaft rotation.
3	V/f Curve	
	V/f Range	Sets the relationship between motor voltage and frequency. A detailed explanation is provided later in this User's Guide.

Drive Configuration

In the Parameter Configuration window, click the Drive Configuration tab to display parameters for configuring the drive (see Figure 2-4). Table 2-4 describes the controls in detail.

Figure 2-4. Drive Configuration Window

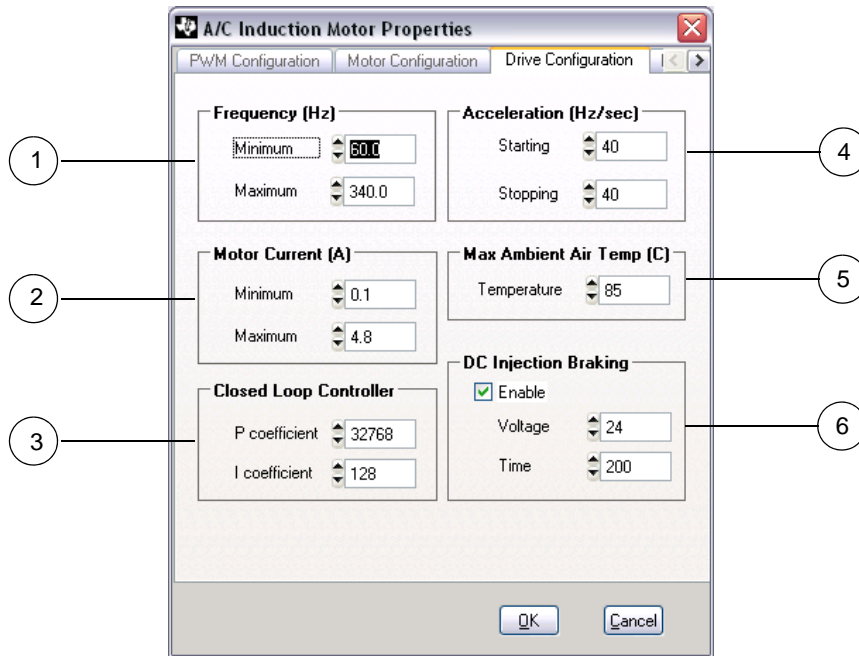

Table 2-4. Description of Drive Configuration Controls

Item No.	Name	Description
1	Frequency	
	Minimum	Sets the minimum motor frequency (speed).
	Maximum	Sets the maximum motor frequency (speed). Use with minimum frequency to define the usable speed range.
2	Motor Current	
	Minimum/Maximum	Sets the limits for motor over and under current.
3	Closed-Loop Controller	
	P/I Coefficients	In Closed-Loop mode, these parameters define the response characteristic of the PI controller. Normally, these parameters can be left at factory default settings.
4	Acceleration	
	Minimum/Maximum	Sets the acceleration and deceleration rates. Reducing these values increases the time the motor takes to change speeds.
5	Max Ambient Air Temp	
	Temperature	Trip point for over temperature trip.
6	DC Injection Braking	
	Enable	Enables or disables DC injection braking.
	Voltage	Sets the DC voltage to the applied during DC injection braking.
	Time	Sets the length of time to apply DC injection braking.

DC Bus Configuration

In the Parameter Configuration window, click the DC Bus Configuration tab to display parameters for configuring the DC bus (see Figure 2-5). Table 2-5 describes the controls in detail.

Figure 2-5. DC Bus Configuration Window

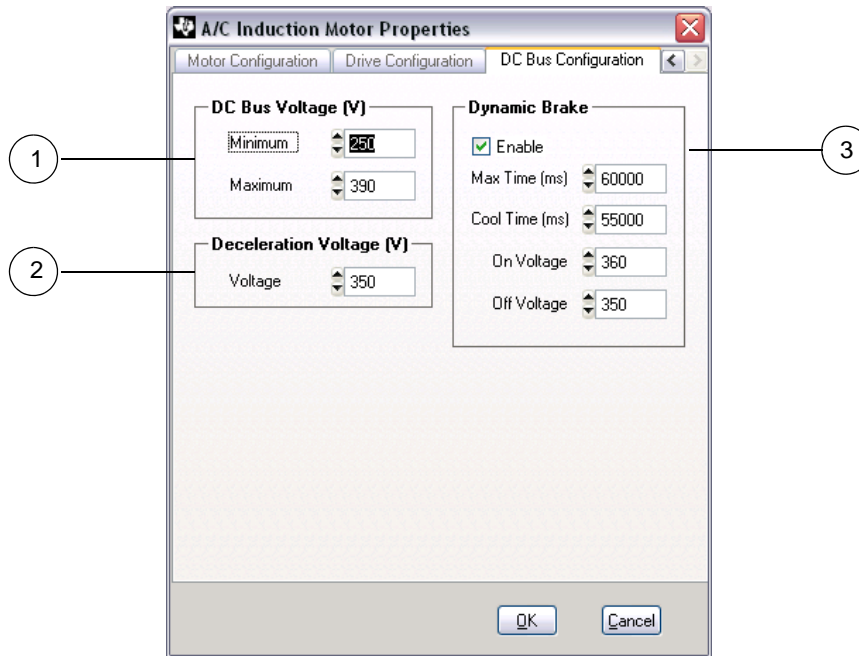

Table 2-5. Description of DC Bus Configuration Controls

Item No.	Name	Description
1	DC Bus Voltage (V)	
	Minimum	Sets the minimum DC bus voltage before a fault is signaled.
	Maximum	Sets the maximum DC bus voltage before a fault is signaled.
2	Deceleration Voltage (V)	
	Voltage	The DC bus voltage at which the deceleration rate is scaled back in an effort to control increases in the DC bus voltage.
3	Dynamic Brake	
	Enable	Turns dynamic braking on. Dynamic braking actively dissipates energy from the motor as it brakes. These settings control the braking levels and dynamic characteristics.
	Max Time (ms)	The maximum amount of time the dynamic brake can be applied before it is forced off to prevent overheating.
	Cool Time (ms)	The time at which the dynamic brake can be reapplied after reaching the Maximum time. The brake is allowed to cool for the delta of Max Time and Cool Time.
	On Voltage	The dynamic brake is applied when the DC bus voltage exceeds this value.
	Off Voltage	Once applied, the dynamic brake is disengaged when the DC bus voltage drops below this level.

Hardware Description

Key components in the reference design include a Stellaris LM3S818 microcontroller with an ARM Cortex-M3 core and a Fairchild Semiconductor FSBS10CH60 Power Module. Other complementary components round out the design by providing protection, signal acquisition, and power supply functions. The entire circuit is built on a simple two-layer printed circuit board. All design files are provided in the RDK CD.

System Description

As is typical for AC-powered motor controls, the microcontroller interfaces directly to the power stage. This scheme allows the microcontroller to directly measure current in the power module, but it also requires that the microcontroller be at high voltage potential with respect to Earth ground. One set of opto-isolators provides electrical isolation for the serial and control signals. A daughter-board, containing a second set of high-speed opto-isolators, isolates the Stellaris microcontroller's JTAG port. Once software development is complete, the JTAG board can be removed to reduce power consumption.

A custom-designed, off-line switching power supply (often called a housekeeping supply), generates three power supply rails, one of which is isolated.

The RDK's line filter, heat sink, and DC bus capacitors are dependent on the end application and are easily customizable. For operation above 0.25 HP, it may be necessary to mount the RDK on an additional heat sink.

Block Diagram

Figure 3-1. Block Diagram

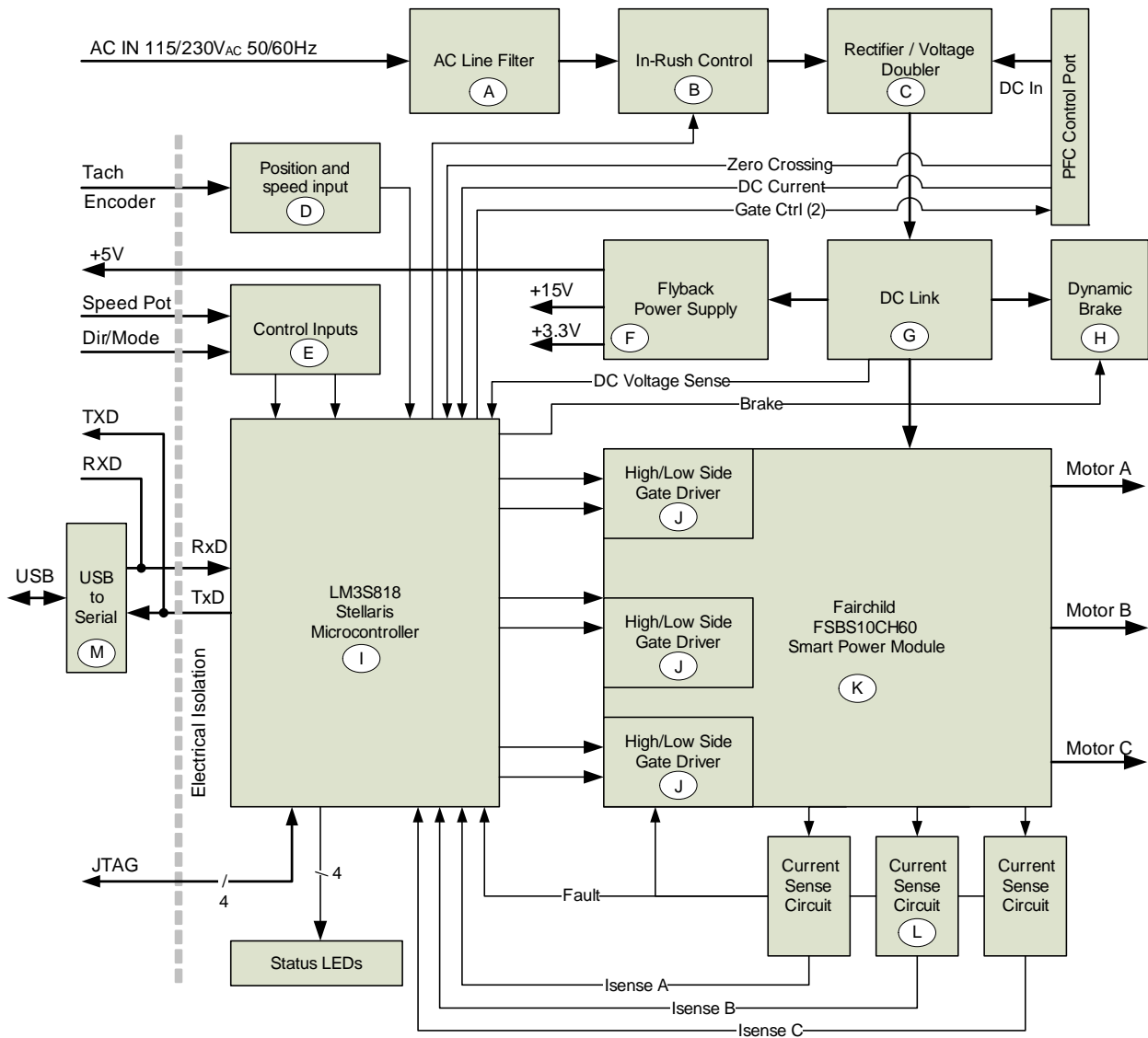

Functional Description

Variable frequency drives are often referred to as inverters, because they convert DC to a variable frequency AC waveform. The key components in this conversion are the microcontroller and the power switching stage, but a lot of peripheral circuitry is needed to make a complete drive. This section describes drive operation in detail.

Microcontroller (Schematic Pages 1-2)

At the core of the AC Induction Motor RDK is a Stellaris LM3S818 microcontroller. The LM3S818 contains a peripheral set that is optimized for three-phase motor control, including 6 high-speed ADC channels, a motor control PWM block, and quadrature encoder inputs.

The RDK has three I/O headers (J6, J7, and J8) in close proximity to the microcontroller. J7 has the JTAG port signals which are used for programming and debugging the microcontroller.

WARNING – Risk of Electric Shock

The microcontroller in the RDK is not referenced to ground; it is at AC line potential. Do not make direct connection to the JTAG header or any other microprocessor-related circuit. Read the Quickstart Guide first for additional warnings.

To allow safe development using JTAG, the RDK includes an optical isolation board for JTAG signals. This is described in detail in the “Isolated JTAG Interface (Schematic Page 6)” on page 31.

Header J8 contains signals for an external power factor correction (PFC) stage. PFC uses an active switching stage to remove harmonics from the AC line current waveform. The LM3S818 microcontroller can eliminate a conventional PFC control chip in this circuit block. When PFC is not in use, a jumper must be installed between J8.3 and J8.4.

Unallocated GPIO signals from the microcontroller are routed to J6. This includes the SSI port which can be connected to a SPI EEPROM or similar device.

NOTE: The GPIO signals are not isolated.

Finally, page 1 of the schematic contains five LEDs. These are also referenced to high voltage.

Output Power Stage (Schematic Page 3)

The most significant component on page 2 is the FSBS10CH60 Smart Power Module (SPM) from Fairchild Semiconductor. This compact DIP-style device contains six low-loss IGBTs, HVIC gate drivers, and protection circuitry, including under-voltage lock-out and short-circuit protection. The SPM has three negative DC terminals allowing independent monitoring of each phase current.

The microcontroller provides the SPM with three pairs of complementary PWM signals, one pair for each phase. A simple RC network on each digital PWM improves noise immunity. Dead-time, the delay between PWM on states, is controlled by the PWM block inside the microcontroller and can be set in software.

The SPM operates from a +15 V_{DC} supply which is carefully capacitor-decoupled to ensure reliable operation during switching. To turn on the high-side IGBTs, the gate voltage must be driven higher than the collector. This is achieved with the usual flying- or bootstrap-capacitor method. Using Phase U as an example: When the low-side IGBT is ON, diode D10 is forward-biased and capacitors C21 and C24 charge to almost 15 V. In turn, this charge allows the high-side IGBT to be turned on by the high-side gate driver. As the high-side IGBT turns on, its emitter voltage rises, taking the negative terminal of the flying capacitor along with it. The capacitor is sized to maintain a high-side supply voltage of at least HV_{DC} + 12.5 V during the ON state. If the capacitor discharges below 11.3 V (typ), the SPM's under-voltage lock-out circuit activates to prevent the IGBT from moving outside its safe operating area (SOA).

Three 40 mΩ resistive shunts provide 40 mV/A current sensing. The resultant voltage is fed to three different circuits (see Table 3-1).

Table 3-1. Current Monitoring Circuits

	SPM Current Trip	Microcontroller Comparator	Microcontroller ADC
Function	Short-circuit (or shoot-through) protection	Software programmable current trip	Measurement of phase current amplitude
Amplifier Gain	n/a	n/a	11
Resolution	n/a	137.5 mV	10 bits
Scale	40 mV/A – 0.15 V	40 mV/A – 0.15 V	1 bit = 6.67 mA
Trip Threshold (typ.)	15 Amps	Programmable reference	In software
Trip Speed (typ.)	<5 us	<10 us	Software-dependent

Isolated Control Interfaces (Schematic Page 4)

Page 4 of the schematics contains both high-voltage and isolated circuitry. Six opto-isolators safely interface various control signals to the microprocessor. The speed control potentiometer forms a simple variable frequency oscillator with U7. The microcontroller determines the potentiometer's position by measuring the frequency on PD5/CCP2.

Three isolated digital inputs accommodate the Mode switch (can also be used for encoder index pulse) and two quadrature encoder signals. The IN_A input has a Schmitt-trigger feature that supports the speed sensor signal from the ATB Selni motor included in the RDK. This type of speed sensor is known as a tacho-generator. A small permanent magnet moves inside a coil of wire generates an AC voltage that is synchronized to the motor's speed. The Schmitt trigger ensures the opto-isolator is fed with a digital signal.

UART0 signals from the microcontroller get isolated by U8 and U13. Jumper JP1 routes the transmit and receive signals to either the USB device or to J4, the control interface terminal block. RXD and TXD on J4 are CMOS level, not RS232 level, so may be directly connected to the UART of an external microcontroller.

Table 3-2. Control Interface Functions

Terminal	Label	Function
1	5V	Aux power out (40mA max)
2	ENA	Encoder Input A or Tach Input
3	ENB	Encoder Input B
4	IDX	Encoder Index Pulse – normally used by Mode switch
5	RXD	UART Receive data (logic level)
6	TXD	UART Transmit data (logic level)

Table 3-2. Control Interface Functions (Continued)

7	0V	Common Ground for Isolated Control Interface
---	----	--

In the factory default mode, UART signals connect to the FT232RL USB device controller (U6) which implements a Virtual COM Port. An isolated +3.3V rail is obtained from the unregulated +5V rail by the FT232RK's internal regulator.

Power Supplies (Schematic Page 5)

The RDK can operate from either 115 V_{AC} or 230 V_{AC}. In the case of 115 V operation, the input diode bridge (D13) is used in conjunction with the bus capacitors (C44 and C45) to create a voltage doubler.

For 115V operation: $HV_{DC}(\text{nom}) = 115 \text{ V} \times 2 \times 1.414 = 325 \text{ V}_{dc}$

For 230V operation: $HV_{DC}(\text{nom}) = 230 \text{ V} \times 1.414 = 325 \text{ V}_{dc}$

The RMS output voltage of the motor control varies from 0 to 230V_{rms} under software control.

Two 200V capacitors, connected in series, provide filtering on the DC bus. Capacitor size and selection is an important parameter when designing motor controls, so the RDK mounts the capacitors off-board to make substitution easy. Double check polarity when changing capacitors. Capacitors are discussed further in the implementation section of this guide.

At power-up the bus capacitors charge through R84 to eliminate in-rush current. The microcontroller monitors the HV_{DC} voltage level and closes a relay (K1) once the capacitors are almost fully charged. This method is a more reliable and efficient method than using a NTC thermistor, though a thermistor may be suitable in some applications.

The RDK also includes a dynamic braking circuit that also operates under software control. If the HV_{DC} bus exceeds a programmable level, the braking circuit is activated to dump power from the HV_{DC} bus until it returns to a safe level. This condition typically occurs during motor deceleration, where the rotor is turning faster than the stator field and regeneration occurs. Due to the size, cost and specificity of braking circuits, the RDK design has a low power brake. Even at 20 Watts, the brake allows the RDK to drastically increase deceleration rates.

The house-keeping power supply uses Fairchild's FSD200 Single-chip SMPS device. A custom transformer has taps for +3.3 V, +15 V, and +5 V, so no linear voltage regulators are necessary. A low-cost feedback circuit (Q5, Q6) replaces the usual optoisolator. Zener diodes on the unregulated rails are installed simply as a precaution during development.

Isolated JTAG Interface (Schematic Page 6)

This section of the schematic is only used during software development. The isolated JTAG interface board can be unplugged from the main board when development is complete. Four high-speed opto-isolators provide electrical isolation for TDI, TDO, TMS, and TCK signals. A lower speed isolator is sufficient for the reset circuit. The reset switch is isolated, but use caution as it is in close proximity to high voltages.

As opto-isolators increase JTAG propagation delays, it may be necessary to reduce the speed of some high-speed JTAG debug interfaces when working with the RDK.

Software

The software running on the Stellaris microcontroller is responsible for generating the waveforms that drive the motor. The motor drive is capable of operation from 0 to 400 Hz with smooth

acceleration and deceleration from 1 to 100 Hz/second. Additionally, it monitors the state of the motor drive and handles fault conditions.

The software is written entirely in C. The RDK CD includes the full source code.

Modulation Methods

The waveforms that drive the motor can be generated using either the sine wave modulation or space vector modulation technique. Sine wave modulation is an easy-to-generate modulation technique, but does not provide full utilization of the DC bus voltage (it provides a peak voltage in the motor of roughly 86% of the DC bus voltage before distortion occurs).

Space vector modulation, on the other hand, allows full utilization of the DC bus voltage but is more complicated to compute. For either modulation technique, the rate at which new points on the waveform is computed can be adjusted, allowing a trade-off between processor usage and waveform quality (a slower update rate will have lower processor usage but also a lower quality waveform).

Other Functions

Monitoring of the DC bus voltage, motor current, power module fault signal, and microcontroller ambient temperature is performed during the operation of the motor drive. Several steps are taken to manage the DC bus voltage; if the motor drive is decelerating and the DC bus voltage exceeds a parameter value (due to regeneration), the rate of deceleration is temporarily decreased. If the DC bus voltage exceeds another parameter value, a dynamic brake is applied to reduce the DC bus voltage.

There are several fault conditions that result in the motor drive being turned off as a safety measure:

- DC bus voltage gets too high (from excessive regeneration)
- DC bus voltage gets too low (usually from a loss of input power)
- Motor current gets too high
- Motor current gets too low
- Power module signals a fault
- Microcontroller ambient temperature gets too high

The fault condition must be manually cleared before the motor drive will operate again.

Motor Control Parameters

The AC induction motor control software has an extensive set of parameters which it stores in on-chip Flash memory. The parameters define both high-level operation (for example, acceleration rate) and low-level operation (for example, modulation algorithm). Because they are stored in flash rather than hard-coded, the parameters can be modified using a serial control protocol. The RDK GUI program provides a visual method for monitoring and adjusting control parameters over the USB interface. An introduction to the RDK GUI can be found in the Quickstart guide.

Parameter Reference

See Appendix A, "Parameters and Real-Time Data Items" for detailed description of the RDK's parameters.

Implementation Considerations

This section provides information on items to consider when implementing the ACIM RDK.

Motor Selection

For new designs, three-phase motors rather than their single-phase counterparts are recommended for use with the RDK. This is due to three-phase motors having higher torque, better efficiency, and wider speed range.

Premium motor models are often qualified by the manufacturer as inverter duty. This implies that the manufacturer has taken measures in the motor design to reduce failures due to the high frequency switching inherent in a PWM-based motor control. Failure modes include insulation breakdown in the stator and bearing pitting. At 230 V or less, the negative effects of high-speed switching are less of a concern. In addition, because the end application may provide a discharge path for any charge that accumulates in the shaft, a motor that is not necessarily inverter duty may be suitable. Regardless, it is still important to address this with your motor supplier.

Bus Capacitors

The bus capacitors (C44, C45) are connected in series to achieve a 400 V rating and to enable the voltage doubler option. For 230 V-only operation, a single capacitor would normally be used.

When electrolytic capacitors are used in a series configuration, it is important that neither capacitor exceeds its individual voltage rating. Because internal impedances can vary, you should consider placing a power resistor in parallel with each capacitor to ensure voltage sharing, especially during power up. At least one manufacturer found that as long as capacitors were from the same batch, voltage divider resistors were unnecessary and could be considered to have a negative effect on overall reliability.

Capacitors are typically the most expensive and shortest-lived components in a motor control system, therefore, selecting the correct part is critical. The ACIM RDK's design enables experimentation with different values, sizes, and temperature ratings. Since heat directly affects capacitor life, capacitor sizes with the greatest surface area are preferable.

Heat Sinking

Underwriters Laboratories (UL) standards generally require that surfaces that could be touched by a user or service person must not exceed 70° C. The RDK control aluminum baseplate may require additional heat sinking to keep it below this limit. Securely mount the control to a larger aluminum heat sink using machine screws and thermal paste or sheet material.

Power Line Filtering

The power entry filter used in the RDK is for evaluation and is not expected to meet compliance limits for conducted emissions. Inverter-based motor controls typically require a multi-stage power line filter tailored to the end application.

Serial Protocol

See the *AC Induction Motor RDK Software Reference Manual* for more information.

A P P E N D I X A

Parameters and Real-Time Data Items

This section provides detailed information for parameters and real-time data items (see “Real-Time Data Items” on page 50).

Parameters

Table A-1 provides a summary of all configuration parameters. See “Parameter Descriptions” on page 37 for more information.

Table A-1. Parameter Configuration Summary

ID	Units	Range	Default	See
Informational Parameters				
PARAM_FIRMWARE_VERSION	number	0 to 65335	varies	page 37
PARAM_MOTOR_STATUS	enumeration	n/a	0	page 38
PARAM_FAULT_STATUS	flags	n/a	0	page 38
Motor Configuration Parameters				
PARAM_MOTOR_TYPE	choice	0 to 1	0	page 39
PARAM_NUM_POLES	count	0 to 255	1	page 39
PARAM_ENCODER_PRESENT	Boolean	0 to 1	1	page 39
PARAM_NUM_LINES	count	0 to 65535	7	page 39
PARAM_VF_RANGE	choice	0 to 1	1	page 40
PARAM_VF_TABLE	1.15 fixed-point integer scale factor	0 to 37837	4200, 5200, 6200, 7200, 8300, 9700, 11500, 13400, 15200, 17050, 18900, 20750, 22550, 24400, 26250, 28100, 29900, 31750, 31750, 31750	page 40
PARAM_MIN_SPEED	1/10 th of a Hertz	0 to 4000	600	page 40
PARAM_MAX_SPEED	1/10 th of a Hertz	0 to 4000	3400	page 41
PARAM_MIN_CURRENT	1/10 th of an ampere	0 to 50	1	page 41
PARAM_MAX_CURRENT	1/10 th of an ampere	0 to 50	48	page 41

Table A-1. Parameter Configuration Summary (Continued)

ID	Units	Range	Default	See
PWM Configuration Parameters				
PARAM_PWM_FREQUENCY	choice	0 to 3	3	page 42
PARAM_PWM_DEAD_TIME	20 nanoseconds	100 to 255	100	page 42
PARAM_PWM_UPDATE	PWM periods	0 to 255	0	page 42
PARAM_PWM_MIN_PULSE	1/10 th of a microsecond	0 to 50	10	page 43
PARAM_PRECHARGE_TIME	milliseconds	0 to 255	2	page 43
Motor Drive Configuration Parameters				
PARAM_MODULATION	choice	0 to 1	0	page 43
PARAM_DIRECTION	Boolean	0 to 1	0	page 44
PARAM_ACCEL	Hertz/second	1 to 100	40	page 44
PARAM_DECEL	Hertz/second	1 to 100	40	page 44
PARAM_TARGET_SPEED	1/10 th of a Hertz	0 to 4000	varies	page 45
PARAM_CURRENT_SPEED	1/10 th of a Hertz	0 to 4000	0	page 45
Dynamic Braking Parameters				
PARAM_USE_DYNAM_BRAKE	Boolean	0 to 1	1	page 45
PARAM_BRAKE_ON_VOLTAGE	volts	1 to 400	360	page 45
PARAM_BRAKE_OFF_VOLTAGE	volts	1 to 400	350	page 46
PARAM_MAX_BRAKE_TIME	milliseconds	0 to 60000	60000	page 46
PARAM_BRAKE_COOL_TIME	milliseconds	0 to 60000	55000	page 46
DC Injection Braking Configuration Parameters				
PARAM_USE_DC_BRAKE	Boolean	0 to 1	1	page 47
PARAM_DC_BRAKE_V	volts	0 to 160	24	page 47
PARAM_DC_BRAKE_TIME	milliseconds	0 to 65535	200	page 47
Closed-Loop Configuration Parameters				
PARAM_CLOSED_LOOP	Boolean	0 to 1	0	page 47
PARAM_SPEED_P	16.16 fixed-point signed integer	-2,147,483,648 to 2,147,483,647	32768	page 48
PARAM_SPEED_I	16.16 fixed-point signed integer	-2,147,483,648 to 2,147,483,647	128	page 48

Table A-1. Parameter Configuration Summary (Continued)

ID	Units	Range	Default	See
DC Bus Configuration Parameters				
PARAM_MIN_BUS_VOLTAGE	volts	1 to 400	250	page 48
PARAM_MAX_BUS_VOLTAGE	volts	1 to 400	390	page 49
PARAM_USE_BUS_COMP	Boolean	0 to 1	1	page 49
PARAM_DECEL_VOLTAGE	volts	1 to 400	350	page 49
Miscellaneous Configuration Parameters				
PARAM_USE_ONBOARD_UI	Boolean	0 to 1	1	page 50
PARAM_MAX_TEMPERATURE	degrees Celsius	0 to 85	85	page 50

Parameter Descriptions

This section describes parameter configuration in detail. The parameters are grouped into the following areas:

- Informational
- Motor
- PWM
- Motor drive
- Dynamic braking
- DC injection braking
- Closed-Loop
- DC bus
- Miscellaneous

Informational Parameters

Firmware Version

ID	Units	Range	Default
PARAM_FIRMWARE_VERSION	number	0 to 65535	varies

This read-only parameter provides the version number of the firmware. Changing the value of this parameter in the source code makes it difficult for Texas Instruments' support personnel to determine the firmware in use when trying to provide assistance; this parameter should only be changed after careful consideration.

Motor Drive Status

ID	Units	Range	Default
PARAM_MOTOR_STATUS	enumeration	n/a	0

This parameter is a read-only value that provides the current operating status of the motor drive. The value will be one of the following:

Value	Meaning
0	The motor drive is stopped.
1	The motor drive is running.
2	The motor drive is accelerating.
3	The motor drive is decelerating.

Motor Drive Fault Status

ID	Units	Range	Default
PARAM_FAULT_STATUS	flags	n/a	0

This parameter is a read-only value that provides the current status of faults in the motor drive. This value is a bit field, with each bit indicating a different fault condition as follows:

Bit	Fault Condition
0	An emergency stop was requested.
1	The DC bus voltage dropped too low.
2	The DC bus voltage rose too high.
3	The motor current dropped too low.
4	The motor current rose too high.
5	The smart power module indicated a fault.
6	The ambient temperature rose too high.

These fault conditions are sticky; any fault condition that has occurred will be indicated. A write of any value to this parameter clears all fault conditions.

The motor drive will not operate while a fault condition is indicated in this parameter.

Motor Configuration Parameters

Motor Type

ID	Units	Range	Default
PARAM_MOTOR_TYPE	choice	0 to 1	0

This parameter specifies whether a single-phase or a three-phase A/C induction motor will be driven by the motor drive. A value of 0 indicates that a three-phase motor is being used and a value of 1 indicates that a single-phase motor is being used.

The value of this parameter can be changed while the motor drive is stopped.

Number of Poles

ID	Units	Range	Default
PARAM_NUM_POLES	count	0 to 255	1

This parameter specifies the number of poles in the motor, minus 1 (since it not possible to have a zero pole motor). This is for information purposes only; it does not affect the behavior or operation of the motor drive. The motor speed in rpm can be computed from this value with the equation:

$$\text{RPM} = 120 * \text{PARAM_CURRENT_FREQUENCY} / (\text{NUMBER_OF_POLES} + 1)$$

This information is obtained from the motor being used, either from the name plate on the motor or from the data sheet for the motor.

Encoder Present

ID	Units	Range	Default
PARAM_ENCODER_PRESENT	Boolean	0 to 1	1

This parameter indicates the presence of an encoder on the rotor shaft. Closed-Loop mode is not permitted if this parameter does not indicate the presence of an encoder.

A parameter value of 1 indicates that an encoder is present. When an encoder is present, the *Number of Encoder Lines* parameter indicates the number of lines in the encoder.

Number of Encoder Lines

ID	Units	Range	Default
PARAM_NUM_LINES	count	0 to 65535	7

This parameter specifies the number of lines in the encoder, minus 1 (since it is not possible to have a zero line encoder). A line corresponds to a rising edge and a falling edge produced by the encoder. This information is used to convert edges from the encoder into the rotor frequency.

V/f Table Range Select

ID	Units	Range	Default
PARAM_VF_RANGE	choice	0 to 1	1

This parameter specifies the range of the V/f table provided in the *V/f Table* parameter. A value of 0 specifies a V/f table range of 0 Hz to 100 Hz, and a value of 1 specifies a V/f table range of 0 Hz to 400 Hz.

For 50/60 Hz motors, a V/f table range of 0 Hz to 100 Hz is the best choice, and also allows the amplitude at 50 Hz to be specified (which is not directly possible with the other range). For high frequency motors (such as 400 Hz aircraft motors), a V/f table range of 0 Hz to 400 Hz is the best choice.

V/f Table

ID	Units	Range	Default
PARAM_VF_TABLE	1.15 fixed-point integer scale factor	0 to 37837	4200, 5200, 6200, 7200, 8300, 9700, 11500, 13400, 15200, 17050, 18900, 20750, 22550, 24400, 26250, 28100, 29900, 31750, 31750, 31750

This table provides a mapping between the motor drive frequency and the amplitude (that is, voltage) of the waveform produced by the motor drive. By increasing the amplitude of the waveform as the frequency increases, the torque produced by the motor is held approximately constant.

This table ranges from 0 Hz to either 100 Hz or 400 Hz, based on the setting of the *V/F Range Select* parameter. The 0-100 range provides an amplitude value every 5 Hz, and the 0-400 range provides a value every 20 Hz. For the 0-100 range, frequencies above 100 Hz are produced at the same amplitude as the 100 Hz entry of the table.

For any frequency, an amplitude that is too high can cause the motor to rotate in an erratic fashion and an amplitude that is too low can cause the motor to fail to rotate.

Minimum Drive Frequency

ID	Units	Range	Default
PARAM_MIN_SPEED	1/10 th of a Hertz	0 to 4000	600

This parameter specifies the minimum frequency at which the motor drive will operate. When running, the output frequency will not go below this frequency. When stopping or reversing

direction, this minimum frequency is ignored and the output frequency will slew all the way down to 0.

The minimum drive frequency should never be set lower than the slowest drive frequency that will turn the motor; setting this parameter lower will result in effort being expended for no gain (the motor simply will not spin).

Maximum Drive Frequency

ID	Units	Range	Default
PARAM_MAX_SPEED	1/10 th of a Hertz	0 to 4000	3400

This parameter specifies the maximum frequency at which the motor drive will operate. The output frequency will never exceed this frequency, even if the target frequency matches the maximum frequency and Closed-Loop mode is enabled (slip in the motor requires that the drive frequency exceed the target frequency).

The maximum drive frequency should never be set higher than the maximum frequency that the motor can handle; setting this parameter higher could result in permanent damage to the motor (mechanical failure from excessive speed, melted winding insulation from excessive heating, and so on).

Minimum Motor Current

ID	Units	Range	Default
PARAM_MIN_CURRENT	1/10 th of an ampere	0 to 50	1

This parameter specifies the minimum RMS current that should be consumed by the motor while operating. If the measured motor RMS current is less than this value, an under-current fault will be triggered and the motor drive will immediately shut down. If this value is zero, the minimum motor current check is disabled.

Maximum Motor Current

ID	Units	Range	Default
PARAM_MAX_CURRENT	1/10 th of an ampere	0 to 50	48

This parameter specifies the maximum RMS current that should be consumed by the motor while operating. If the measured motor RMS current is greater than this value, an over-current fault will be triggered and the motor drive will immediately shut down. If this value is zero, the maximum motor current check is disabled.

PWM Configuration Parameters

PWM Frequency

ID	Units	Range	Default
PARAM_PWM_FREQUENCY	choice	0 to 3	3

This parameter selects the frequency of the PWM signals used to drive the inverter bridge. The PWM frequency can be 8 KHz (parameter value 0), 12.5 KHz (parameter value 1), 16 KHz (parameter value 2), or 20 KHz (parameter value 3).

Higher PWM frequencies produce less audible noise in the motor windings (though there may be little or no PWM frequency-induced audible noise in the windings of high quality motors). Higher PWM frequencies also cause higher processor usage due to an increased interrupt rate.

PWM Dead Time

ID	Units	Range	Default
PARAM_PWM_DEAD_TIME	20 nanoseconds	100 to 255	100

This parameter specifies the amount of time to delay between turning off one gate on a phase and turning on the other gate. The dead time is required since the turn on and turn off times of the gates do not always match, and the times for the high-side and low-side gates do not always match. This time delay prevents shoot-through current that would occur if both gates were on at the same time (which is a short between the DC bus and ground).

While the dead time prevents damage to the motor and motor drive, it also introduces harmonic distortion into the drive waveforms.

The dead time required by the smart power module on the RDK-ACIM board is 2 uS; this parameter can not be decreased. It can be increased in order to evaluate the performance of the motor with a larger dead time (before building a custom board with a different inverter that required a longer dead time).

Waveform Update Rate

ID	Units	Range	Default
PARAM_PWM_UPDATE	PWM periods	0 to 255	0

This parameter specifies the number of PWM periods that occur between recomputations of the output waveforms. The parameter value is the number of periods minus 1; for example, a parameter value of 4 means that the waveform is recomputed every 5 PWM periods.

Smaller update rates mean more frequent recomputation of the output waveform. This results in higher quality waveforms (with less harmonic distortion) at the cost of increased processor usage.

There is an indirection relationship between this parameter, the *PWM Frequency* parameter, and the *Maximum Drive Frequency* parameter. The *PWM Frequency* combined with the *Waveform Update Rate* determines the *Maximum Drive Frequency* that can be produced by the motor drive without aliasing in the output waveforms. The following equation must be true:

$$\text{PWM Frequency} / (\text{PARAM_PWM_UPDATE} + 1) \geq \text{PARAM_MAX_FREQUENCY} * 8$$

What this means is that there must be at least 8 computations of the waveform for every cycle of the output waveform (that is, the angle step at each computation should be ≥ 45 degrees).

This relation is not enforced by the firmware.

Minimum PWM Pulse Width

ID	Units	Range	Default
PARAM_PWM_MIN_PULSE	1/10 th of a microsecond	0 to 50	10

This parameter provides the width of the smallest PWM pulse that will be generated by the motor drive. If the motor drive attempts to produce a PWM pulse that is shorter than this value, it will lengthen the PWM pulse to this value.

Small PWM pulses are removed since they do no useful work. By the time the gate has turned on and is starting to let current flow, it is turned off again by the short pulse. In order to avoid switching that performs no useful work, the pulse is lengthened.

Lengthening PWM pulses results in the introduction of harmonic distortion in the output waveforms.

High-side Gate Driver Precharge Time

ID	Units	Range	Default
PARAM_PRECHARGE_TIME	milliseconds	0 to 255	2

This parameter specifies the amount of time to precharge the high-side gate driver before starting to drive waveforms to the inverter bridge. The high-side gate drivers have a charge pump that generates the voltage required to drive the high-side gates; this charge pump only operates when there is switching on the corresponding low-side gate. The high-side gate drivers are precharged by driving 50% duty cycle PWM signals to only the low-side gate drivers for the specified time period.

Setting this value too low results in trying to drive PWM signal to the high-side gate drivers before they can turn on the high-side gates. This results in PWM signals that do not make it to the motor. This is a brief phenomenon, and it is typically harmless to bypass the precharge step. Setting this value too high simply results in an increased delay before the motor starts spinning.

Motor Drive Configuration Parameters

Modulation Type

ID	Units	Range	Default
PARAM_MODULATION	choice	0 to 1	0

This parameter selects the modulation type to be used to drive the motor. A value of 0 indicates that sine wave modulation will be used, and a value of 1 indicates that space vector modulation will

be used. Sine wave modulation is the only accepted modulation type when a single-phase motor is being driven.

Sine wave modulation is easy to understand but only provides 86.6% utilization of the DC bus. Space vector modulation is more complicated but provides 100% utilization of the DC bus. Better utilization of the DC bus results in more output torque from the motor.

The value of this parameter can not be changed while the motor drive is running.

Motor Drive Direction

ID	Units	Range	Default
PARAM_DIRECTION	Boolean	0 to 1	0

This parameter specifies the direction of rotation for the motor drive. Since the motor drive has no knowledge of the connection of the windings to the drive, it can not be said that one particular value means clockwise rotation and the other means counter-clockwise rotation. Changing the value of this parameter reverses the direction of rotation.

The value of this parameter can only be changed for three-phase motors; this parameter is forced to 0 for single-phase motors.

Acceleration Rate

ID	Units	Range	Default
PARAM_ACCEL	Hertz/second	1 to 100	40

This parameter is the rate at which the output frequency increases when it is less than the target frequency. When in Closed-Loop mode, this is the maximum rate of acceleration that is allowed, though lower acceleration rates can be utilized.

The rate of acceleration can also be viewed as the rate that slip is introduced into the motor drive. Slip causes an increase in the current through the motor, so setting the acceleration too high may result in the over-current fault tripping due to excessive slip.

Deceleration Rate

ID	Units	Range	Default
PARAM_DECEL	Hertz/second	1 to 100	40

This parameter is the rate at which the output frequency decreases when it is greater than the target frequency. If the DC bus voltage exceeds the value of the *DC Bus Deceleration Voltage* parameter, the value of this parameter will be temporarily scaled back to slow the rise in the DC bus voltage. If the DC bus voltage is below the *DC Bus Deceleration Voltage* parameter and this parameter was previously scaled back, it will be slewed back to the parameter value at a rate of ¼ Hz/sec every millisecond. When in Closed-Loop mode, this is the maximum rate of deceleration that is allowed, though lower deceleration rates can be utilized.

Setting this parameter value too high may result in DC bus voltage increases that can not be handled by deceleration rate scaling and dynamic braking. In this case, a DC bus over-voltage fault will occur.

Target Drive Frequency

ID	Units	Range	Default
PARAM_TARGET_SPEED	1/10 th of a Hertz	0 to 4000	varies

This parameter specifies the target frequency of the motor drive. In Open-Loop mode, this is the output frequency of the motor drive. In Closed-Loop mode, this is the frequency of the rotor. Note that in Closed-Loop mode, the target frequency should not exceed the maximum drive frequency minus the motor slip frequency; if it does, then the motor drive will never be able to achieve the target rotor speed (since the output frequency can never exceed the maximum drive frequency).

This parameter value must lie between the *Minimum Drive Frequency* and the *Maximum Drive Frequency*.

Current Drive Frequency

ID	Units	Range	Default
PARAM_CURRENT_SPEED	1/10 th of a Hertz	0 to 4000	0

This parameter is a read-only value that provides the current output frequency of the motor drive. This is the same value that is provided using the *Current Stator Frequency* real-time data item.

Dynamic Braking Configuration Parameters

Dynamic Braking Enable

ID	Units	Range	Default
PARAM_USE_DYNAM_BRAKE	Boolean	0 to 1	1

This parameter specifies whether dynamic braking should be used; a value of 1 enables dynamic braking and a value of 0 disables it.

Dynamic braking is the use of a power resistor to control the increase in the DC bus voltage caused by decelerating an A/C induction motor. By using dynamic braking, the motor can be decelerated at a faster rate since the added DC bus voltage rise is counteracted by the power resistor.

Dynamic Brake Engage Voltage

ID	Units	Range	Default
PARAM_BRAKE_ON_VOLTAGE	volts	1 to 400	360

This parameter specifies the DC bus voltage at which the braking resistor is enabled. The braking resistor converts voltage on the DC bus into heat in an attempt to reduce the voltage level on the DC bus.

If this value is too low, the braking resistor could be turned on all the time. If it is too high, the braking resistor may never be turned on (or it may turn on immediately before an over-voltage

fault). The value of this parameter must be greater than the value of the *Dynamic Brake Disengage Voltage* parameter, though this is not enforced by the firmware.

Dynamic Brake Disengage Voltage

ID	Units	Range	Default
PARAM_BRAKE_OFF_VOLTAGE	volts	1 to 400	350

This parameter specifies the DC bus voltage at which the braking resistor is disabled.

If this value is too low, the braking resistor may never turn off once enabled; if it is too high, the braking resistor may not stay on for very long or it may cycle on and off very quickly. The value of this parameter must be less than the value of the *Dynamic Brake Engage Voltage* parameter, though this is not enforced by the firmware.

Maximum Dynamic Braking Time

ID	Units	Range	Default
PARAM_MAX_BRAKE_TIME	milliseconds	0 to 60000	60000

This parameter specifies the maximum amount of accumulated time that the dynamic brake can be on. Turning on the power resistor causes it to generate heat; turning it off causes that heat to dissipate. A counter increases when the power resistor is on and decreases when it is off. If the counter reaches the value of this parameter, the power resistor is turned off regardless of the DC bus voltage to prevent overheating of the power resistor. Once forced off, the counter must decrease to the value of the *Dynamic Brake Cooling Time* parameter before it can be turned on again (giving it time to cool down before being used again).

If the value of this parameter is too small, the motor drive will not be able to make effective use of the power resistor to control the DC bus voltage. If the value of this parameter is too large, the power resistor may overheat, resulting in permanent damage.

The value of this parameter must be larger than the value of the *Dynamic Brake Cooling Time* parameter, though this is not enforced by the firmware.

Dynamic Brake Cooling Time

ID	Units	Range	Default
PARAM_BRAKE_COOL_TIME	milliseconds	0 to 60000	55000

This parameter specifies the value the dynamic brake counter must reach in order to re-enable the power resistor if it has been forced off. See the description of the *Maximum Dynamic Braking Time* parameter for details.

The value of this parameter must be less than the value of the *Maximum Dynamic Braking Time* parameter, though this is not enforced by the firmware.

DC Injection Braking Configuration Parameters

DC Injection Braking Enable

ID	Units	Range	Default
PARAM_USE_DC_BRAKE	Boolean	0 to 1	1

This parameter specifies whether DC injection braking should be used; a value of 1 enables DC injection braking and a value of 0 disables it.

DC injection braking is the application of DC voltage to an A/C induction motor in order to make it stop quickly. This is a form of electrical braking that does not involve any friction components (such as a mechanical brake) and therefore, does not result in any wear. Use DC injection braking with caution since applying DC voltage to a stopped A/C induction motor will quickly increase the temperature in the motor windings, possibly causing permanent damage.

DC Injection Braking Voltage

ID	Units	Range	Default
PARAM_DC_BRAKE_V	volts	0 to 160	24

This parameter specifies the DC voltage to be applied to the motor when performing DC injection braking. The higher the voltage applied, the more braking and the more potentially damaging to the motor if left on for too long. See the description of the *DC Injection Braking Enable* parameter for more details.

DC Injection Braking Time

ID	Units	Range	Default
PARAM_DC_BRAKE_TIME	milliseconds	0 to 65535	200

This parameter specifies the amount of time to perform DC injection braking. Leaving DC injection braking on for too long could cause permanent damage to the motor. See the description of the *DC Injection Braking Enable* parameter for more details.

Closed-Loop Configuration Parameters

Closed-Loop Mode Enable

ID	Units	Range	Default
PARAM_CLOSED_LOOP	Boolean	0 to 1	0

This parameter selects between Open-Loop and Closed-Loop mode of the motor drive. In Open-Loop mode, the output frequency is set to the target frequency and the rotor spins at the frequency determined by its slip. In Closed-Loop mode, the rotor frequency is monitored and the output frequency is set so that the rotor frequency matches the target frequency.

A parameter value of 1 enables Closed-Loop mode. Closed-Loop mode is not possible (and this parameter can not be set to 1) if there is not an encoder present on the rotor (as indicated by the *Encoder Present* parameter).

When in Closed-Loop mode, the *Frequency Controller P Coefficient* and *Frequency Controller I Coefficient* are used to tune the PI controller that forms the feedback loop.

Frequency Controller P Coefficient

ID	Units	Range	Default
PARAM_SPEED_P	16.16 fixed-point signed integer	-2,147,483,648 to 2,147,483,647	32768

This parameter is the P coefficient of the PI controller used to adjust the frequency of the motor drive while in Closed-Loop mode. The P coefficient adjusts the output frequency based on the error in the most recently sampled rotor speed (known as the proportional term). In 16.16 fixed point notation, 65536 corresponds to 1.0 (that is, the proportional term is equal to the error).

Larger values of the P coefficient result in a decrease in the rise time of the output in response to a step input, an increase in the overshoot, and a decrease in the steady state error. Smaller values do the opposite. For effective operation of the PI controller, the *Frequency Controller I Coefficient* should also be set.

Frequency Controller I Coefficient

ID	Units	Range	Default
PARAM_SPEED_I	16.16 fixed-point signed integer	-2,147,483,648 to 2,147,483,647	128

This parameter is the I coefficient of the PI controller used to adjust the frequency of the motor drive while in Closed-Loop mode. The I coefficient adjusts the output frequency based on the integral of all past errors in the sampled rotor speed (known as the integral term). In 16.16 fixed point notation, 65536 corresponds to 1.0 (that is, the integral term is equal to the integrator value).

Larger values of the I coefficient result in a decrease in the rise time of the output in response to a step input, an increase in the overshoot, and an elimination of the steady state error. Smaller values do the opposite (though the steady state error will always be eliminated by non-zero I coefficients). For effective operation of the PI controller, the *Frequency Controller P Coefficient* should also be set.

DC Bus Configuration Parameters

Minimum DC Bus Voltage

ID	Units	Range	Default
PARAM_MIN_BUS_VOLTAGE	volts	1 to 400	250

This parameter specifies the minimum DC bus voltage that should be present on the motor drive. If the DC bus voltage drops below this value, an under-voltage fault will be triggered and the motor drive will immediately shut down.

This will typically only occur when the mains input to the board is disconnected (or the mains power goes out).

Maximum DC Bus Voltage

ID	Units	Range	Default
PARAM_MAX_BUS_VOLTAGE	volts	1 to 400	390

This parameter specifies the maximum DC bus voltage that should be present on the motor drive. If the DC bus voltage goes above this value, an over-voltage fault will be triggered and the motor drive will immediately shut down.

Caution – When the motor is being decelerated it acts like a generator, increasing the DC bus voltage. If the motor is decelerated too quickly, the DC bus voltage will rise too high. Left unhandled, the elevated DC bus voltage could cause permanent damage to components on the motor drive board (such as the DC bus capacitors, which are rated for 400 volts).

DC Bus Voltage Compensation Enable

ID	Units	Range	Default
PARAM_USE_BUS_COMP	Boolean	0 to 1	1

This parameter specifies whether DC bus voltage ripple compensation should be utilized; a value of 1 enables ripple compensation and a value of 0 disables it.

Operation of the motor drive results in fluctuations on the DC bus voltage. By measuring the DC bus voltage and providing instantaneous adjustments to the amplitude of the drive waveform, the motor is presented with a voltage that is closer to the desired voltage since the bus ripple has been removed.

DC Bus Deceleration Voltage

ID	Units	Range	Default
PARAM_DECEL_VOLTAGE	volts	1 to 400	350

This parameter specifies the DC bus voltage at which the deceleration rate is reduced. A slower deceleration will result in a smaller increase in the DC bus voltage. The deceleration rate is decreased proportional to the amount by which the DC bus voltage exceeds the value of this parameter, with the deceleration reduced to ¼ Hz/sec when the DC bus voltage is 64 V above this parameter. Therefore, this acts more aggressively as the DC bus voltage gets higher.

To avoid bouncing the DC bus voltage and therefore, the deceleration rate, a reduced deceleration rate is slowly increased by ¼ Hz every millisecond when the DC bus voltage is below the value of this parameter.

Setting the value of this parameter too low (that is, below the normal DC bus voltage) will result in the motor decelerating slower than it could or should. Setting the value of this parameter too high

will result in the ineffective control of the DC bus voltage. Setting the value of this parameter at or above the value of the *Maximum DC Bus Voltage* parameter will effectively disable this feature.

Miscellaneous Parameters

On-board User Interface Enable

ID	Units	Range	Default
PARAM_USE_ONBOARD_UI	Boolean	0 to 1	1

This parameter determines whether the on-board user interface elements can be used to control the motor drive. If the value of this parameter is 1, the on-board user interface will control the motor drive; if 0 they will not.

The motor drive can always be operated over the serial interface. But, the target frequency is constantly updated by the on-board user interface when enabled, making that parameter effectively uncontrollable from the serial interface when the on-board user interface is enabled.

The on-board user interface is disabled by the ACIM GUI upon startup and re-enabled on exit.

Maximum Ambient Temperature

ID	Units	Range	Default
PARAM_MAX_TEMPERATURE	degrees Celsius	0 to 85	85

This parameter specifies the maximum ambient temperature that is allowed. If the ambient temperature exceeds this value, an over-temperature fault will be triggered and the motor drive will immediately shut down.

The ambient temperature is an approximation of the ambient temperature on the top of the microcontroller's package (which is relatively removed from the heat sink and the smart power module which generates a majority of the heat). The junction temperature of the microcontroller is measured with the ADC and the on-chip temperature sensor and used to approximate the ambient temperature as determined by lab characterization of the transfer function.

Real-Time Data Items

Table A-2 provides a summary of all real-time data items. See "Real-Time Data Items Descriptions" on page 51 for more information.

Table A-2. Real-Time Data Items

ID	Units	Range	Default	See
Drive Status				
DATA_MOTOR_STATUS	enumeration	n/a	varies	page 51
DATA_FAULT_STATUS	flags	n/a	varies	page 51
DATA_PROCESSOR_USAGE	%	0 to 100	varies	page 52

Table A-2. Real-Time Data Items (Continued)

ID	Units	Range	Default	See
Motor Speed				
DATA_STATOR_SPEED	1/10 th of a Hertz	0 to 4000	varies	page 52
DATA_ROTOR_SPEED	1/10 th of a Hertz	0 to 4000	varies	page 52
Measurement				
DATA_BUS_VOLTAGE	volts	0 to 400	varies	page 52
DATA_PHASE_A_CURRENT	1/256 th of an ampere	0 to 65535	varies	page 53
DATA_PHASE_B_CURRENT	1/256 th of an ampere	0 to 65535	varies	page 53
DATA_PHASE_C_CURRENT	1/256 th of an ampere	0 to 65535	varies	page 53
DATA_MOTOR_CURRENT	1/256 th of an ampere	0 to 65535	varies	page 53
DATA_TEMPERATURE	degrees Celsius	0 to 85	varies	page 53

Real-Time Data Items Descriptions

This section describes the real-time data items in detail. The data items are grouped into two areas: motor speed and measurement.

Drive Status Parameters

Motor Drive Status

ID	Units	Range
DATA_MOTOR_STATUS	enumeration	n/a

This real-time data item provides the current status of the motor drive. This is the same data in the same format as the *Motor Drive Status* parameter.

Motor Drive Fault Status

ID	Units	Range
DATA_FAULT_STATUS	flags	n/a

This real-time data item provides the current fault status of the motor drive. This is the same data in the same format as the *Motor Drive Fault Status* parameter.

Processor Usage

ID	Units	Range
DATA_PROCESSOR_USAGE	%	0 to 100

This real-time data item provides the percentage of the processor being used.

Motor Speed Parameters

Current Stator Frequency

ID	Units	Range
DATA_STATOR_SPEED	1/10 th of a Hertz	0 to 4000

This real-time data item provides the current frequency of the waveforms being driven to the inverter bridge. Once driven to the motor, this is the frequency of the magnetic field rotating through the stator of the motor.

Current Rotor Frequency

ID	Units	Range
DATA_ROTOR_SPEED	1/10 th of a Hertz	0 to 4000

This real-time data item provides the current frequency of the motor's rotor. If an encoder is not present, this will always be 0. The value of this real-time data item will always be less than the value of the *Current Stator Frequency* real-time data item due to the slip inherent in A/C induction motors (in fact, the difference between the two is the slip frequency).

Measurement Parameters

DC Bus Voltage

ID	Units	Range
DATA_BUS_VOLTAGE	volts	0 to 400

This real-time data item provides the DC bus voltage. The DC bus under-voltage and over-voltage faults trigger based on the value of this real-time data item, and the dynamic braking and reduced deceleration controls operated based on this value as well.

Motor Phase U Current

ID	Units	Range
DATA_PHASE_A_CURRENT	1/256 th of an ampere	0 to 65535

This real-time data item provides the RMS current for the U phase of the motor. This is found by performing a peak-detect across a full cycle of the drive waveform and dividing the peak value by $\sqrt{2}$ to find the RMS current.

Motor Phase V Current

ID	Units	Range
DATA_PHASE_B_CURRENT	1/256 th of an ampere	0 to 65535

This real-time data item provides the RMS current for the V phase of the motor. See the *Motor Phase U Current* real-time data item for the computation method.

Motor Phase W Current

ID	Units	Range
DATA_PHASE_C_CURRENT	1/256 th of an ampere	0 to 65535

This real-time data item provides the RMS current for the W phase of the motor; this will not be valid for a single-phase motor since it does not have a W phase. See the *Motor Phase U Current* real-time data item for the computation method.

Motor Current

ID	Units	Range
DATA_MOTOR_CURRENT	1/256 th of an ampere	0 to 65535

This real-time data item provides the RMS current for the entire motor. For a single-phase motor, this is the same as the U and V phase RMS currents (the two are averaged). For a three-phase motor, this is $\sqrt{3}$ times the RMS current through a single phase (the three-phase currents are averaged). The motor under-current and over-current faults trigger based on the value of this real-time data item.

Ambient Temperature

ID	Units	Range
DATA_TEMPERATURE	degrees Celsius	0 to 85

This real-time data item provides the ambient temperature on the top of the microcontroller's package, as inferred by measuring the microcontroller's junction temperature. The over-temperature fault triggers based on the value of this real-time data item.

Schematics

This section contains the schematics for the ACIM Motor Control Board:

- Contents Page on page 56
- Microcontroller on page 57
- Power Stage on page 58
- Isolated Control Interfaces on page 59
- Power Supplies on page 60
- Isolated JTAG Interface on page 61

AC Induction Motor Control RDK

Table of Contents

Page	Description
1	Table of Contents and Revision History
2	Stellaris Microcontroller, LED indicators
3	Power Module Stage
4	Isolated Control Interfaces
5	Power Supplies
6	Isolated JTAG Interface

Revision History

Revision	Date	Description
0	Jan 14, 07	First Full Release for Rev 0 PCB
0.1	Feb 08, 07	Add rework changes. T1 pin swap. Add Brake pull-up.
A	Feb 20, 07	Improve Reset circuit. Add Tach Gen support. Fix JTAG. Release to Production.

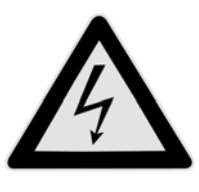

CAUTION
Risk of Electric Shock

All circuits are high-voltage unless otherwise noted.
DC rail labels refer to voltage with respect to HVDC GND
which is at AC line potential.

TEXAS INSTRUMENTS		
Drawing Title: ACIM Reference Design		
Page Title: Contents Page		
Size: B	Document Number:	
Date: 2/20/2007	Sheet 1 of 6	Rev A

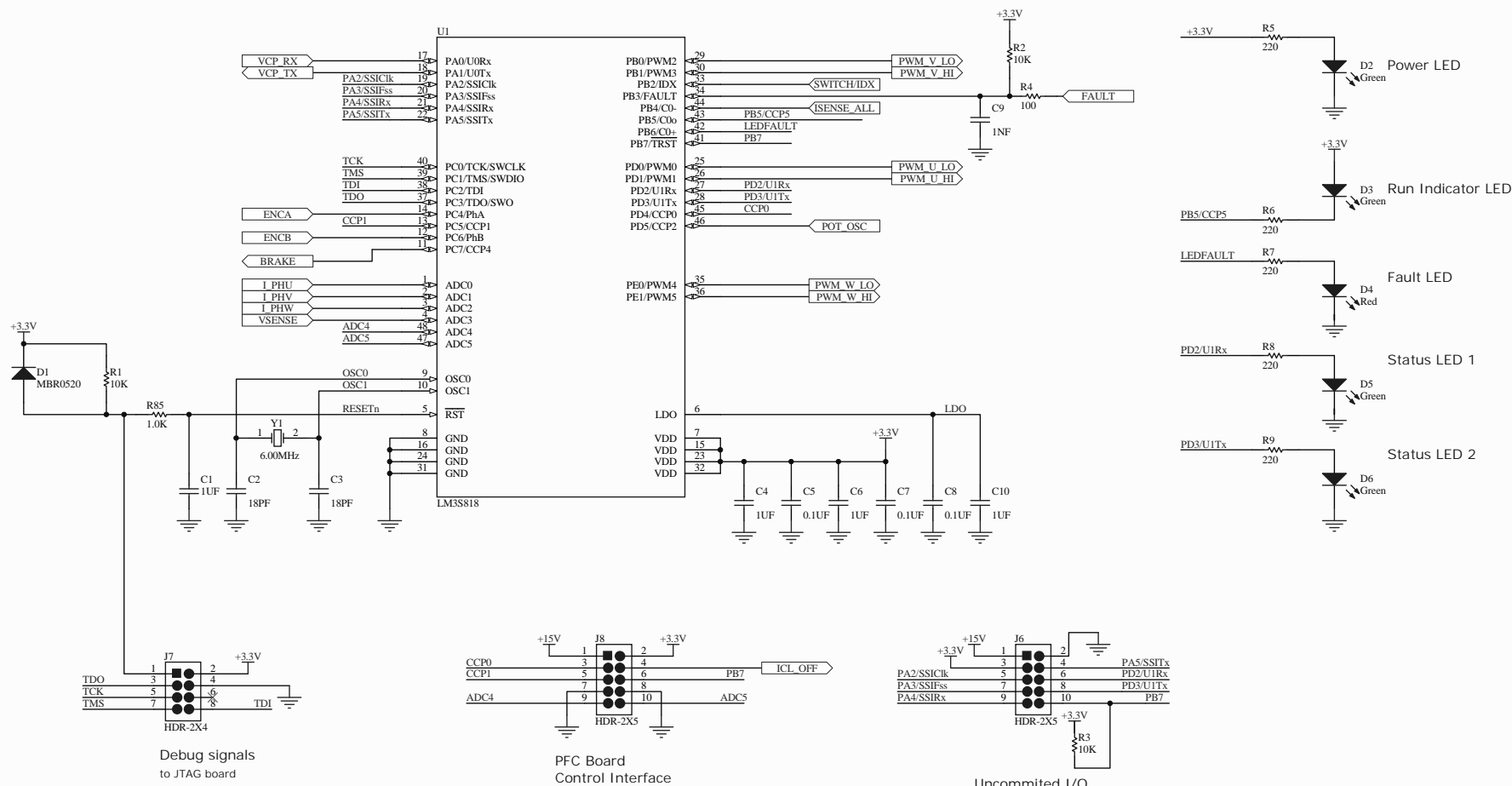

TEXAS INSTRUMENTS

Drawing Title: ACIM Reference Design

Page Title: MCU etc

Size B Document Number:

Date: 2/20/2007 Sheet 2 of 6 Rev A

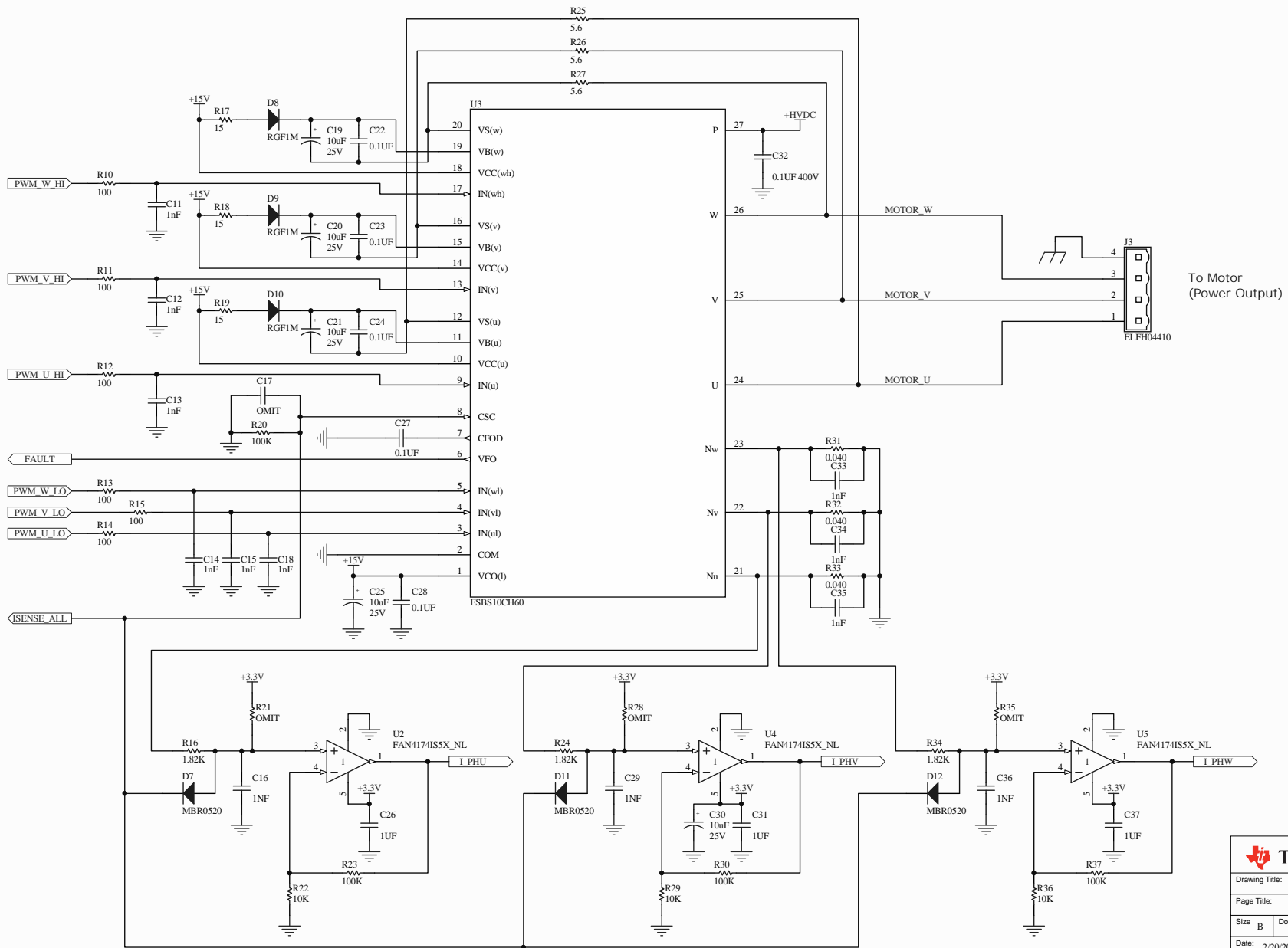

CAUTION
Risk of Electric Shock

Texas Instruments	
Drawing Title: ACIM Reference Design	
Page Title: Power Stage	
Size B	Document Number:
Date: 2/20/2007	Sheet 3 of 6 Rev A

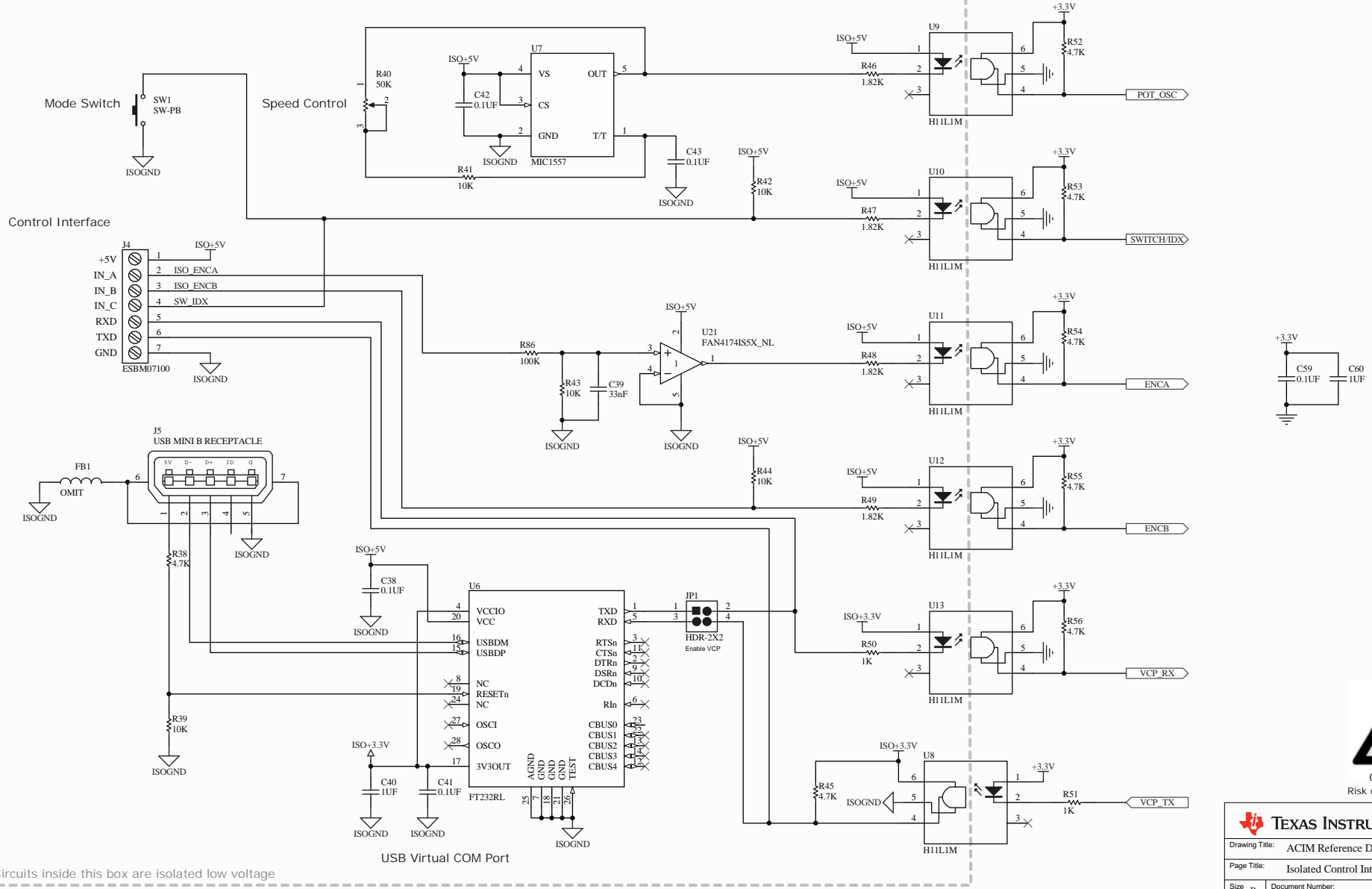

Circuits inside this box are isolated low voltage



CAUTION
Risk of Electric Shock

Drawing Title: ACIM Reference Design		
Page Title: Isolated Control Interfaces		
Size B	Document Number:	
Date: 2/20/2007	Sheet 4 of 6	Rev A

230VAC +/- 15%
LINE INPUT

115VAC +/- 15%
LINE INPUT

Isolated +5V Supply

ISO+5V ISO+3.3V
H9 HDR-2X2
ISOLATED POWER TO JTAG BD.

Flyback Converter
15V 60mA, 3.3V 200mA, 5V 65mA

Braking Circuit

DC Link Stage

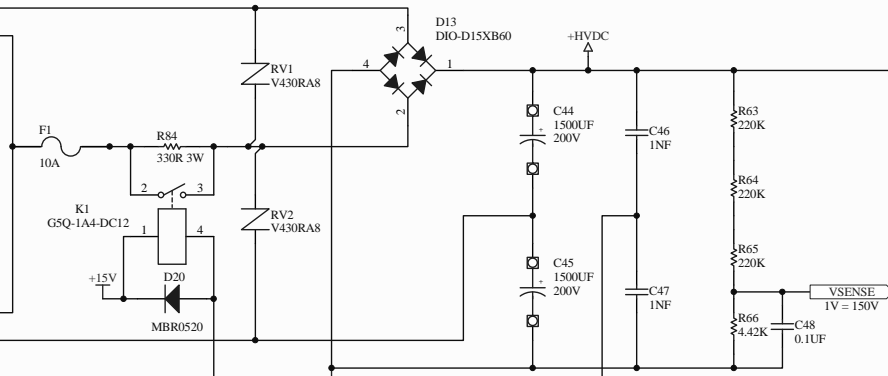
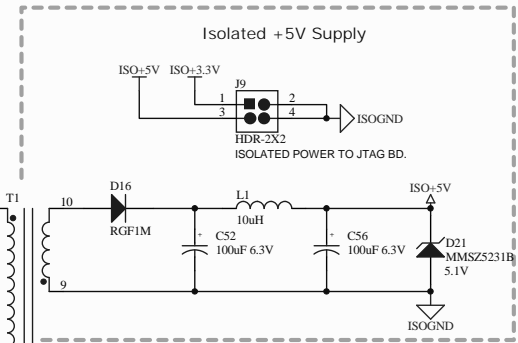
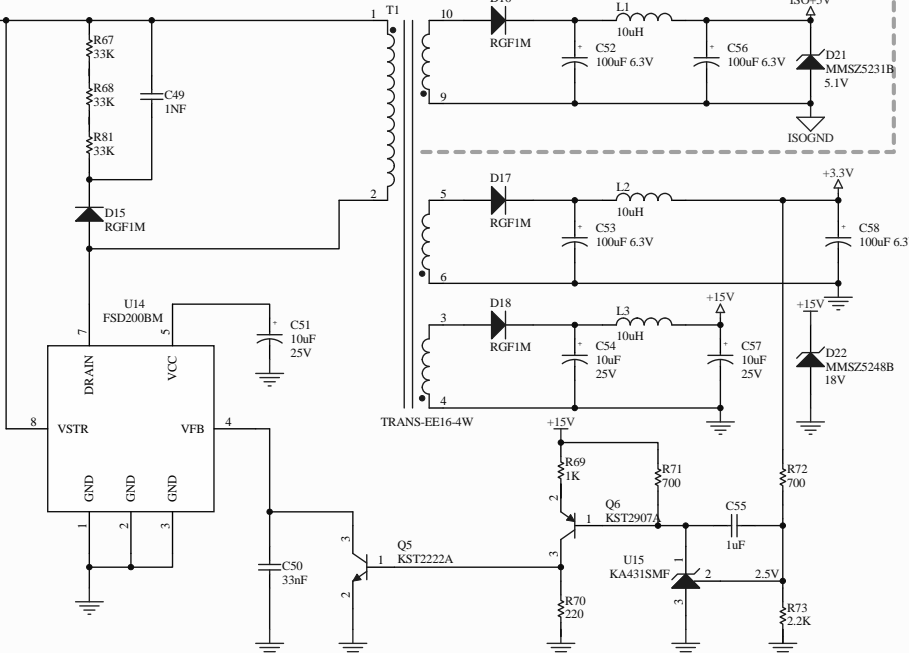
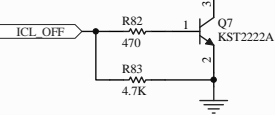
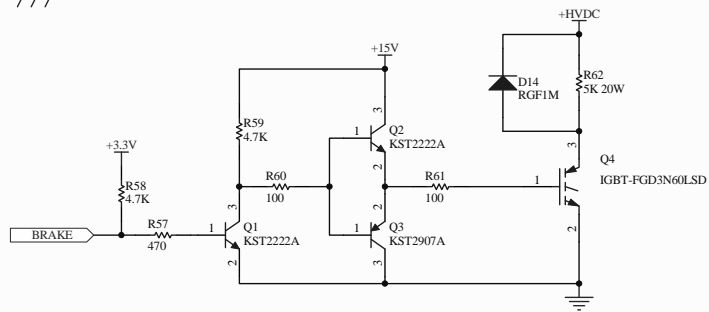
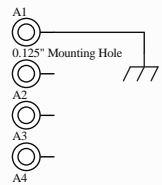

TEXAS INSTRUMENTS	
Drawing Title: ACIM Reference Design	
Page Title: Power Supplies	
Size B	Document Number:
Date: 2/20/2007	Sheet 5 of 6 Rev A



CAUTION
Risk of Electric Shock

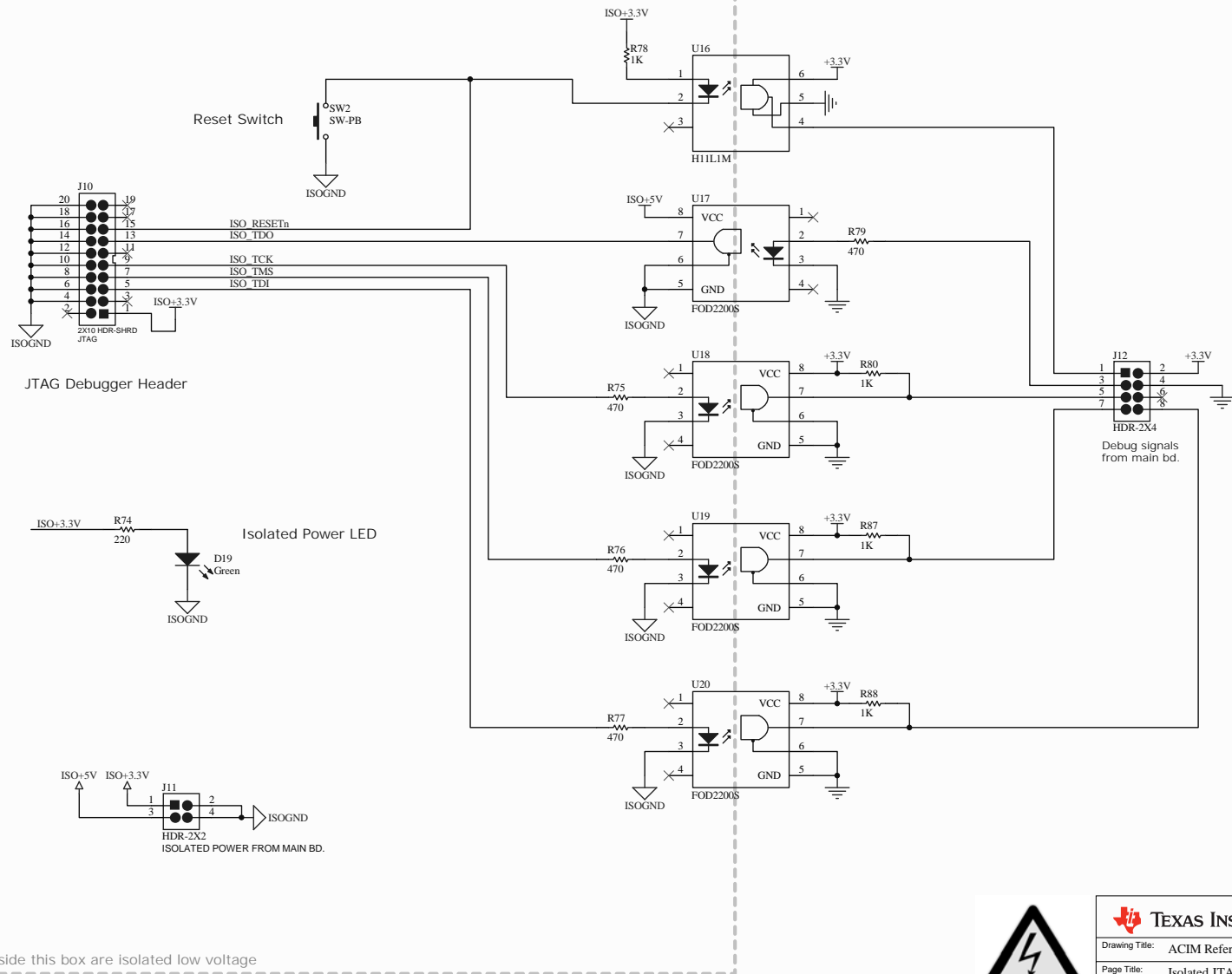

CAUTION
Risk of Electric Shock

Drawing Title: ACIM Reference Design	
Page Title: Isolated JTAG Interface	
Size B	Document Number:
Date: 2/20/2007	Sheet 6 of 6 Rev A

A P P E N D I X C

PCB Component Locations

This section shows the PCB component locations for the ACIM RDK.

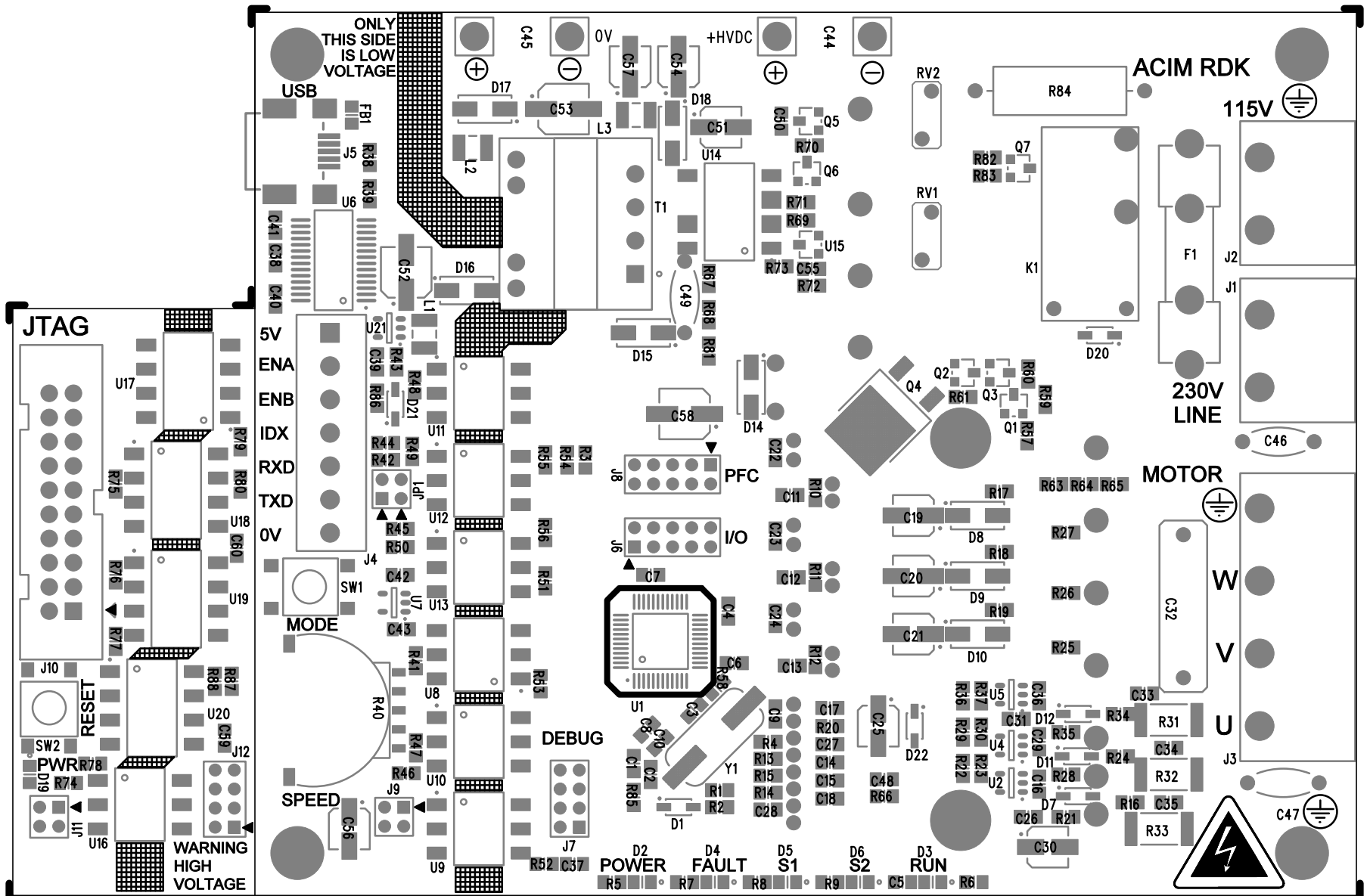

A P P E N D I X D

Bill of Materials (BOM)

This section provides the BOM for the ACIM RDK.

Texas Instruments, Inc.
AC Induction Motor Control RDK
Bill Of Materials
Revision A-1

2/20/2007

Item	Designator	Qty	Ordering	Description	MFG
1	C5, C7, C8, C22, C23, C24, C27, C28, C38, C41, C42, C43, C48, C59	14	C0805C104J5RACTU	Capacitor 0.1uF 0805 50V X7R 5%	Kemet
2	C19, C20, C21, C25, C30, C51, C54, C56, C57	9	EEE-FK1E100R	Capacitor, 10uF 25V Electro, Low Z, SMT Size B	Panasonic
3	C52, C53, C58	3	EEE-FK0J101UR	Capacitor 100uF 6.3V Electro, Low Z, SMT Size C	Panasonic
4	C1, C4, C6, C10, C26, C31, C37, C40, C55, C60	10	C0805C105Z4VACTU	Capacitor 1uF 16V Y5V 0805	Kemet
5	C2, C3	2	C0805C180J5G	Capacitor 18pF 0805 NPO 50v 5%	Kemet
6	C9, C11, C12, C13, C14, C15, C16, C18, C29, C33, C34, C35, C36	13	C0805C102K5RACTU	Capacitor 1000pF 0805 X7R 50V 10%	Kemet
7	C32	1	B32652A4104J	Capacitor 0.1uF Polypropylene Film 400V	EPCOS
8	C44a, C44b, C45a, C45b	4	8730	Terminal, Single pos open screw type	Keystone
9	C49	1	GP210	Capacitor 1000pF Ceramic 1kV 7.5mm	Mallory
10	C46, C47	2	ECK-ATS102ME	Capacitor 1000pF Ceramic 250Vac 7.5mm Y2/X1	Panasonic
11	C39, C50	2	C0805C333K5RACTU	Capacitor 0.033uF 0805 X7R 50V 10%	Kemet
12	D1, D7, D11, D12, D20	5	MBR0520L	Diode Schottky 20V 500mA	Fairchild
13	D2, D3, D5, D6, D19	5	LTST-C171GKT	LED, 0805 SMT Green	LiteOn
14	D4	1	LTST-C171CKT	LED, 0805 SMT Red	LiteOn
15	D8, D9, D10, D14, D15, D16, D17, D18	8	RGF1M	Diode Fast 1000V 1A	Fairchild
16	D13	1	RS1505M	Rectifier Bridge 15A 600V SIL (Mount on Bottom Side of PCB)	Rectron
17	D22	1	MMSZ5248B	Diode, Zener 18V 500mW SOD-123	Fairchild
18	D21	1	MMSZ5231B	Diode, Zener 5.1V 500mW SOD-123	Fairchild
19	F1	1	5ST 10-R	Fuse, 5x20mm 10A slow-blow	Bel Fuse
20	F1a, F1b	2	3517	Fuse Clip 5mm 15A	Keystone
21	J4	1	ED555/7DS	Terminal Block 7 pos LP 3.5mm black	OST
22	J5	1	54819-0572	Connector, USB Mini-B SMT 5pin	Molex
23	J7	1	PRPN042PAEN-RC	Header 8 pos 2x4 2mm pitch	Molex
24	J6, J8	2	87831-1020	Header 10 pos 2x5 2mm pitch	Molex
25	JP1, J9	2	87831-0420	Header 4 pos 2x2 2mm pitch	Molex
26	J11	1	PPPN022AFCN-RC	Socket 4 pos 2x2 2mm pitch (Mount on Bottom Side of PCB)	Molex
27	J12	1	PPPN042AFCN-RC	Socket 4 pos 2x4 2mm pitch (Mount on Bottom Side of PCB)	Molex
28	J3	1	31266104	7.5mm Terminal Block Header 4 position horizontal	RIA Connect
29	J1, J2	2	31266102	7.5mm Terminal Block Header 2 position horizontal	RIA Connect
30	J10	1	N2520-6002RB	Header 2x10 0.1" pitch shrouded black	3M
31	K1	1	G5Q-1A4-DC12	Relay, SPNO, 10A 12V 200mW coil	Omron

32	L1, L2, L3	3	NLCV32T-100K-PF	Inductor 10uH 450mA	TDK
33	Q1, Q2, Q5, Q7	4	KST2222AMTF	NPN Bipolar Transistor SOT-23	Fairchild
34	Q3, Q6	2	KST2907AMTF	PNP Bipolar Transistor SOT-23	Fairchild
35	Q4	1	FGD3N60LSD	IGBT (N-Channel) 600V DPAK	Fairchild
36	R3	1	EVU-TUAB16B54	Trimpot, 16mm thumbwheel style SMT 50K	Panasonic
37	R1, R2, R3, R22, R29, R36, R39, R41, R42, R43, R44	11		Resistor 10K 1% 0805	Generic
38	R4, R10, R11, R12, R13, R14, R15, R60, R61	9		Resistor 100 Ohm 5% 0805	Generic
39	R5, R6, R7, R8, R9, R70, R74	7		Resistor 220 Ohms 5% 0805	Generic
40	R16, R24, R34, R46, R47, R48, R49	7		Resistor 1.82K 1% 0805	Generic
41	R17, R18, R19	3		Resistor 15 Ohms 5% 0805	Generic
42	R20, R23, R30, R37, R86	5		Resistor 100K 1% 0805	Generic
43	R25, R26, R27	3		Resistor 5.6 Ohms 5% 0805	Generic
44	R31, R32, R33	3	WSL2512R0400FEB LR2512-01-R040-F	Resistor 0.040 Ohms 1% 1W 2512	Vishay
45	R38, R45, R52, R53, R54, R55, R56, R58, R59, R83	10		Resistor 4.7K 5% 0805	Generic
46	R50, R51, R69, R78, R80, R85, R87, R88	8		Resistor 1.0K 1% 0805	Generic
47	R57, R75, R76, R77, R79, R82	6		Resistor 470 Ohms 5% 0805	Generic
48	R62	1	MP925-5.00K-1%	Resistor 5K 25W TO-220 (Mount on Bottom Side of PCB)	Caddock
49	R63, R64, R65	3		Resistor 221K 1% 0805	Generic
50	R66	1		Resistor 4.42K 1% 0805	Generic
51	R67, R68, R81	3		Resistor 33K 5% 0805	Generic
52	R71, R72	2		Resistor 698 Ohms 1% 0805	Generic
53	R73	1		Resistor 2.2K 5% 0805	Generic
54	R84	1	43F330E	Resistor 330 Ohms 5% 3W Silicone	Ohmite
55	RV1, RV2	2	ERZ-V05D431	Industrial High Energy 430V Metal-Oxide Varistor MOV	Panasonic
56	SW1, SW2	2	B3S-1000	Switch, Momentary Tact SMT	Omron
57	T1	1	TSD-2308 PA2115NL	Transformer E16 verticle with 15V, 3.3V and 5V sec	Premier Mag Pulse Eng
58	U6	1	FT232RL	USB UART Asynchronous Serial Data Transfer Chip, SSOP28 Pb-free	FTDI
59	U7	1	MIC1557YM5TR	IC, RC Oscillator SOT23-5	Micrel
60	U8, U9, U10, U11, U12, U13, U16	7	H11L1-SM	Optocoupler High Speed SMT	Fairchild
61	U1	1	LM3S818-IQN20-B0P	IC Microcontroller ARM Cortex-M3 TQFP48	Texas Instruments
62	U2, U4, U5, U21	4	FAN4174IS5X_NL	Single Low-Voltage, Low-Power, Rail-to-Rail Output, 3MHz Op Amp SOT-23	Fairchild
63	U3	1	FSBS10CH60	3-ph IGBT Smart Power Module 600V 10A (Mount on Bottom Side of PCB)	Fairchild
64	U14	1	FSD200BM	Off-line Flyback converter IC, SMT	Fairchild
65	U15	1	KA431SAMFTF	Adjustable Shunt Regulator IC, SOT23	Fairchild
66	U17, U18, U19, U20	4	FOD2200S	Optocoupler High Speed SMT	Fairchild
67	Y1	1	FOXSDLF/060-20	Crystal, 6.00MHz HC49US SMT	Fox
68	PCB	1	ACIMRDK-A	PCB, 3.65"x5.55" 2-layer, 2oz Cu, Bk masks	Generic

Final Assembly Items

69		2	618	Steel Bracket	Keystone
70		1		Aluminum base-plate 5.25x6.75" 4mm	Generic
71		4	91290A120	Cap Screw M3 x 16 socket head blk steel	McMasterCarr
72		4	90353A001	Machine screw M2.5 x 4 Pan Head Slotted Steel	McMasterCarr
73		3	91290A109	Cap Screw M3 x 4 socket head blk steel	McMasterCarr
74		1	91290A111	Cap Screw M3 x 6 socket head blk steel	McMasterCarr
75		4	91290A113	Cap Screw M3 x 8 socket head blk steel	McMasterCarr
76		2	90591A121	Hex Nut M3 Zinc plated steel	McMasterCarr
77		1	858-10/015	Line Filter Module with IEC socket 10A 115/230V	Qualtek
78		4	R30-6011102	Metric Spacers M3 x 11mm Brass 4.75mm O/D	Harwin
79		1	3527C	Fuse Cover - insulating	Keystone
80		2	222	Steel Clip - C size	Keystone
81		2	DLMSPM-5-01	Spacer, 5/16" white nylon 0.125" hole	Richco
82		4	SJ-5018	Rubber Feet Black Square	3M
83	JP1.1-2, JP1.3-4, J8.3-4	3	M22-1900005	Jumper shunt 2mm gold	Harwin
84	C44, C45	2	EET-UQ2D152CA	Capacitor, Electro 1500uF 20%, 200V 50x25mm	Panasonic
85		2	19003-0040	Insulated Spade Terminal 0.25" 16-14	Molex
86		2	3057-BLACK	Hook-up Wire 16AWG Black 3" cut length	Alpha
87		1	31262104	Terminal Block Plug 4 pos 0.3" pitch black	RIA Connect
88		1	31262102	Terminal Block Plug 2 pos 0.3" pitch black	RIA Connect

46

Notes

Do not populate = C17, FB1, R21, R28, R35

IMPORTANT NOTICE

Texas Instruments Incorporated and its subsidiaries (TI) reserve the right to make corrections, modifications, enhancements, improvements, and other changes to its products and services at any time and to discontinue any product or service without notice. Customers should obtain the latest relevant information before placing orders and should verify that such information is current and complete. All products are sold subject to TI's terms and conditions of sale supplied at the time of order acknowledgment.

TI warrants performance of its hardware products to the specifications applicable at the time of sale in accordance with TI's standard warranty. Testing and other quality control techniques are used to the extent TI deems necessary to support this warranty. Except where mandated by government requirements, testing of all parameters of each product is not necessarily performed.

TI assumes no liability for applications assistance or customer product design. Customers are responsible for their products and applications using TI components. To minimize the risks associated with customer products and applications, customers should provide adequate design and operating safeguards.

TI does not warrant or represent that any license, either express or implied, is granted under any TI patent right, copyright, mask work right, or other TI intellectual property right relating to any combination, machine, or process in which TI products or services are used. Information published by TI regarding third-party products or services does not constitute a license from TI to use such products or services or a warranty or endorsement thereof. Use of such information may require a license from a third party under the patents or other intellectual property of the third party, or a license from TI under the patents or other intellectual property of TI.

Reproduction of TI information in TI data books or data sheets is permissible only if reproduction is without alteration and is accompanied by all associated warranties, conditions, limitations, and notices. Reproduction of this information with alteration is an unfair and deceptive business practice. TI is not responsible or liable for such altered documentation. Information of third parties may be subject to additional restrictions.

Resale of TI products or services with statements different from or beyond the parameters stated by TI for that product or service voids all express and any implied warranties for the associated TI product or service and is an unfair and deceptive business practice. TI is not responsible or liable for any such statements.

TI products are not authorized for use in safety-critical applications (such as life support) where a failure of the TI product would reasonably be expected to cause severe personal injury or death, unless officers of the parties have executed an agreement specifically governing such use. Buyers represent that they have all necessary expertise in the safety and regulatory ramifications of their applications, and acknowledge and agree that they are solely responsible for all legal, regulatory and safety-related requirements concerning their products and any use of TI products in such safety-critical applications, notwithstanding any applications-related information or support that may be provided by TI. Further, Buyers must fully indemnify TI and its representatives against any damages arising out of the use of TI products in such safety-critical applications.

TI products are neither designed nor intended for use in military/aerospace applications or environments unless the TI products are specifically designated by TI as military-grade or "enhanced plastic." Only products designated by TI as military-grade meet military specifications. Buyers acknowledge and agree that any such use of TI products which TI has not designated as military-grade is solely at the Buyer's risk, and that they are solely responsible for compliance with all legal and regulatory requirements in connection with such use.

TI products are neither designed nor intended for use in automotive applications or environments unless the specific TI products are designated by TI as compliant with ISO/TS 16949 requirements. Buyers acknowledge and agree that, if they use any non-designated products in automotive applications, TI will not be responsible for any failure to meet such requirements.

Following are URLs where you can obtain information on other Texas Instruments products and application solutions:

Products

Amplifiers	amplifier.ti.com
Data Converters	dataconverter.ti.com
DLP® Products	www.dlp.com
DSP	dsp.ti.com
Clocks and Timers	www.ti.com/clocks
Interface	interface.ti.com
Logic	logic.ti.com
Power Mgmt	power.ti.com
Microcontrollers	microcontroller.ti.com
RFID	www.ti-rfid.com
RF/IF and ZigBee® Solutions	www.ti.com/lprf

Applications

Audio	www.ti.com/audio
Automotive	www.ti.com/automotive
Broadband	www.ti.com/broadband
Digital Control	www.ti.com/digitalcontrol
Medical	www.ti.com/medical
Military	www.ti.com/military
Optical Networking	www.ti.com/opticalnetwork
Security	www.ti.com/security
Telephony	www.ti.com/telephony
Video & Imaging	www.ti.com/video
Wireless	www.ti.com/wireless

Mailing Address: Texas Instruments, Post Office Box 655303, Dallas, Texas 75265
Copyright © 2009, Texas Instruments Incorporated